NEET 2018 Question Paper with Solutions

Physics - 2018

Topic – Thermal physics

Concept – Thermodynamics

Subject Concept – Thermodynamic process

Concept Field – Work done by gas

Question Level – Easy

Expected time to solve – 40 sec

1. The volume (V) of a monatomic gas varies with its temperature (T), as shown in the graph. The ratio of work done by the gas, to the heat absorbed by it, when it undergoes a change from state A to state B, is

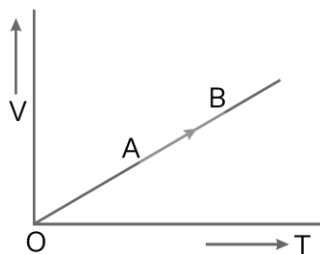

(1) $\frac{1}{3}$

(2) $\frac{2}{3}$

(3) $\frac{2}{5}$

(4) $\frac{2}{7}$

Sol. (3)

Given process is isobaric
 $dQ = nC_p dT \Rightarrow dQ = n \left(\frac{5}{2} R \right) dT$

$$\text{Required ratio} = \frac{dW}{dQ} = \frac{nRdT}{n \left(\frac{5}{2} R \right) dT} = \frac{2}{5}$$

Topic – Waves

Concept – Organ pipe

Subject Concept – Harmonics

Concept Field – Length of organ pipe

Question Level – Easy

Expected time to solve – 40 sec

Concept Field – Efficiency

Question Level – Easy

Expected time to solve – 40 sec

4. The efficiency of an ideal heat engine working between the freezing point and boiling point of water, is
- (1) 6.25% (2) 20% (3) 26.8% (4) 12.5%

Sol. (3)

Efficiency of ideal heat engine, $\eta = \left(1 - \frac{T_2}{T_1} \right)$

T_2 : Sink temperature

T_1 : Source temperature

$$\% \eta = \left(1 - \frac{T_2}{T_1} \right) \times 100 = \left(1 - \frac{273}{373} \right) \times 100 = \left(\frac{100}{373} \right) \times 100 = 26.8\%$$

Topic – Electromagnetism

Concept – Current electricity

Subject Concept – Electric resistance

Concept Field – Carbon resistor

Question Level – Easy

Expected time to solve – 40 sec

5. A carbon resistor of $(47 \pm 4.7) \text{ k}\Omega$ is to be marked with rings of different colours for its identification. The colour code sequence will be
- (1) Yellow – Green – Violet – Gold (2) Yellow – Violet – Orange – Silver
(3) Violet – Yellow – Orange – Silver (4) Green – Orange – Violet – Gold

Sol. (2)

$$(47 \pm 4.7) \text{ k}\Omega = 47 \times 10^3 \pm 10\%$$

\therefore Yellow – Violet – Orange – Silver

Topic – Electrostatics

Concept – electricity and magnetism

Subject Concept – Electric circuit

Concept Field – Connection of resistance

Question Level – Easy

Expected time to solve – 60 sec

6. A set of 'n' equal resistors, of value 'R' each, are connected in series to a battery of emf 'E' and internal resistance 'R'. The current drawn is I. Now, the 'n' resistors are connected in parallel to the same battery. Then the current drawn from battery becomes 10 I. The value of 'n' is

- (1) 20 (2) 11 (3) 10 (4) 9

Sol. (3)

$$I = \frac{E}{nR + R} \quad \dots(i),$$

$$10I = \frac{E}{\frac{R}{n} + R} \quad \dots(ii)$$

Dividing (ii) by (i),

$$10 = \frac{\frac{(n+1)R}{n} + R}{\frac{R}{n} + R}$$

After solving the equation, $n = 10$.

Topic – Electromagnetism

Concept – Current electricity

Subject Concept – Electric circuit

Concept Field – Electric current

Question Level – Easy

Expected time to solve – 40 sec

7. A battery consists of a variable number 'n' of identical cells (having internal resistance 'r' each) which are connected in series. The terminals of the battery are short-circuited and the current I is measured. Which of the graphs shows the correct relationship between I and n?

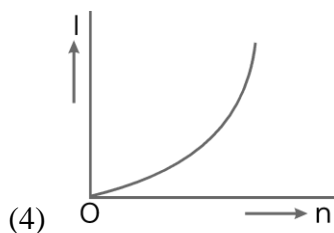
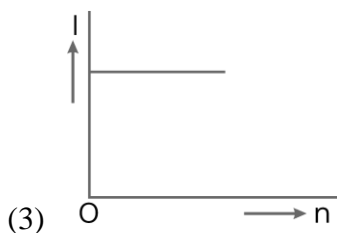
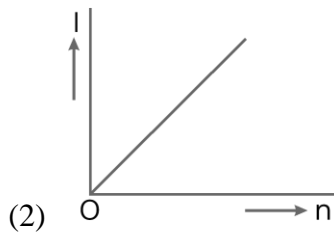
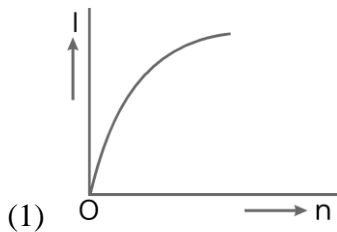

Sol. (3)

$$I = \frac{n\varepsilon}{nr} = \frac{\varepsilon}{r}$$

So, I is independent of n and I is constant.

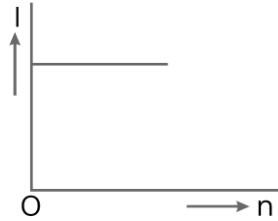

Topic – Optics

Concept – Ray optics

Subject Concept – Refraction

Concept Field – Refractive index

Question Level – Easy

Expected time to solve – 40 sec

8. Unpolarised light is incident from air on a plane surface of a material of refractive index ' μ '. At a particular angle of incidence ' i ', it is found that the reflected and refracted rays are perpendicular to each other. Which of the following options is correct for this situation?

(1) $i = \sin^{-1}\left(\frac{1}{\mu}\right)$

(2) Reflected light is polarised with its electric vector perpendicular to the plane of incidence

(3) Reflected light is polarised with its electric vector parallel to the plane of incidence

(4) $i = \tan^{-1}\left(\frac{1}{\mu}\right)$

Sol. (2)

When reflected light rays and refracted rays are perpendicular, reflected light is polarised with electric field vector perpendicular to the plane of incidence.

10. An astronomical refracting telescope will have large angular magnification and high angular resolution, when it has an objective lens of
- (1) Large focal length and large diameter
 - (2) Large focal length and small diameter
 - (3) Small focal length and large diameter
 - (4) Small focal length and small diameter

Sol. (1)

For telescope, angular magnification = $\frac{f_o}{f_E}$

So, focal length of objective lens should be large.

Angular resolution = $\frac{D}{1.22 \lambda}$ should be large. So, objective should have large focal length (f_o) and

large diameter D.

Topic – Modern physics

Concept – Atomic physics



Subject Concept – H-atom

Concept Field – Kinetic energy

Question Level – Easy

Expected time to solve – 40 sec

11. The ratio of kinetic energy to the total energy of an electron in a Bohr orbit of the hydrogen atom, is
- (1) 2 : -1
 - (2) 1 : -1
 - (3) 1 : 1
 - (4) 1 : -2

Sol. (2)

$$KE = -(\text{total energy})$$

So, Kinetic energy: total energy = 1 : -1

Topic – Dual nature of radiation and matter

Concept – Radiation

Subject Concept – De-Broglie wavelength

Concept Field – Microscope

Question Level – Moderate

Expected time to solve – 75 sec

12. An electron of mass m with an initial velocity $\vec{V} = v_0 \hat{i}$ ($V_0 > 0$) enters an electric field $\vec{E} = -E_0 \hat{j}$ ($E_0 = \text{constant} > 0$) at $t = 0$. If λ_0 is its de-Broglie wavelength initially, then its de-Broglie wavelength at time t is

- (1) $\lambda_0 t$ (2) $\lambda_0 \left(1 + \frac{eE_0 t}{mV_0} \right)$ (3) $\frac{\lambda_0}{\left(1 + \frac{eE_0 t}{mV_0} \right)}$ (4) λ_0

Sol. (3)

Initial de-Broglie wavelength

$$\lambda_0 = \frac{h}{mV_0} \quad \dots(i)$$

Acceleration of electron, $a = \frac{eE_0}{m}$

Velocity after time 't', $V = \left(v_0 + \frac{eE_0 t}{m} \right)$

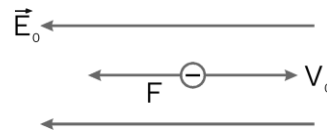

So, $\lambda = \frac{h}{mV} = \frac{h}{m \left(v_0 + \frac{eE_0 t}{m} \right)} = \frac{h}{mV_0 \left(1 + \frac{eE_0 t}{mV_0} \right)} = \frac{\lambda_0}{\left(1 + \frac{eE_0 t}{mV_0} \right)} \quad \dots(ii)$

Divide (ii) by (i),

$$\lambda = \frac{\lambda_0}{\left[1 + \frac{eE_0 t}{mV_0} \right]}$$

Topic – Modern physics

Concept – Nuclear physics

Subject Concept – Radioactive decay

Concept Field – Half life

Question Level – Easy

Expected time to solve – 40 sec

13. For a radioactive material half-life is 10 minutes. If initially are 600 number of nuclei, the time taken (in minutes) for the disintegration of 450 nuclei is

- (1) 30 (2) 10 (3) 20 (4) 15

Sol. (3)

Number of nuclei remaining = $600 - 450 = 150$

$$\frac{N}{N_0} = \left(\frac{1}{2}\right)^t \Rightarrow \frac{150}{600} = \left(\frac{1}{2}\right)^{t/10}$$

$$\left(\frac{1}{2}\right)^2 = \left(\frac{1}{2}\right)^{t/10} \Rightarrow t = 2 \times 10 = 20 \text{ minute}$$

Topic – Modern physics

Concept – Photo electric effect

Subject Concept – Emission of electron

Concept Field – Frequency

Question Level – Easy

Expected time to solve – 40 sec

14. When the light of frequency $2\nu_0$ (where ν_0 is threshold frequency), is incident on a metal plate, the maximum velocity of electrons emitted is ν_1 . When the frequency of the incident radiation is increased to $5\nu_0$, the maximum velocity of electrons emitted from the same plate is ν_2 . The ratio



of ν_1 to ν_2 is

(1) 4 : 1

(2) 1 : 4

(3) 1 : 2

(4) 2 : 1

Sol. (3)

$$E = W_0 + \frac{1}{2}mv^2 \Rightarrow h(2\nu_0) = h\nu_0 + \frac{1}{2}mv_1^2$$

$$h\nu_0 = \frac{1}{2}mv_1^2 \quad \dots(i)$$

$$h(5\nu_0) = h\nu_0 + \frac{1}{2}mv_2^2 \Rightarrow 4h\nu_0 = \frac{1}{2}mv_2^2 \quad \dots(ii)$$

Divide (i) by (ii),

$$\frac{1}{4} = \frac{\nu_1^2}{\nu_2^2} \Rightarrow \frac{\nu_1}{\nu_2} = \frac{1}{2}$$

Topic – Modern physics

Concept – Semiconductor

Subject Concept – Transistor

Concept Field – CE configuration

Question Level – Moderate

Expected time to solve – 50 sec

15. In the circuit shown in the figure, the input voltage V_i is 20 V, $V_{BE} = 0$ and $V_{CE} = 0$. The values of I_B , I_C and β are given by

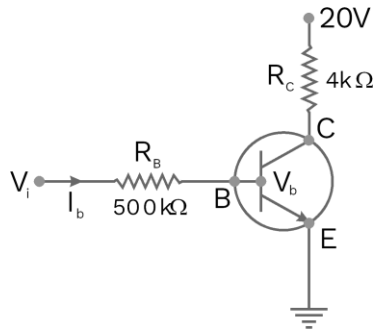

- (1) $I_B = 20 \mu\text{A}$, $I_C = 5 \text{ mA}$, $\beta = 250$ (2) $I_B = 25 \mu\text{A}$, $I_C = 5 \text{ mA}$, $\beta = 200$
 (3) $I_B = 40 \mu\text{A}$, $I_C = 10 \text{ mA}$, $\beta = 250$ (4) $I_B = 40 \mu\text{A}$, $I_C = 5 \text{ mA}$, $\beta = 125$

Sol. (4) $V_{BE} = 0$, $V_{CE} = 0$, $V_b = 0$



$$I_C = \frac{(20-0)}{4 \times 10^3} \Rightarrow I_C = 5 \times 10^{-3} = 5 \text{ mA}$$

$$V_i = V_{BE} + I_B R_B \Rightarrow 20 = 0 + I_B \times 500 \times 10^3 \Rightarrow I_B = \frac{20}{500 \times 10^3} = 40 \mu\text{A}$$

$$\beta = \frac{I_C}{I_B} = \frac{5 \times 10^{-3}}{40 \times 10^{-6}} = 125$$

Topic – Modern physics
Concept – Semiconductor
Subject Concept – p-n junction
Concept Field – Effect of temperature
Question Level – Easy
Expected time to solve – 50 sec

16. In a p-n junction diode, change in temperature due to heating

- (1) Does not affect resistance of p-n junction

- (2) Affects only forward resistance
- (3) Affects only reverse resistance
- (4) Affects the overall V - I characteristics of p-n junction

Sol. (4)

Due to heating, number of electron-hole pairs will increase, so overall resistance of diode will change. Due to which forward biasing and reversed biasing both are changed.

Topic – Modern physics

Concept – Logic gate

Subject Concept – Combination of gates

Concept Field – Boolean algebra

Question Level – Easy

Expected time to solve – 45 sec

17. In the combination of the following gates the output Y can be written in terms of inputs A and B as

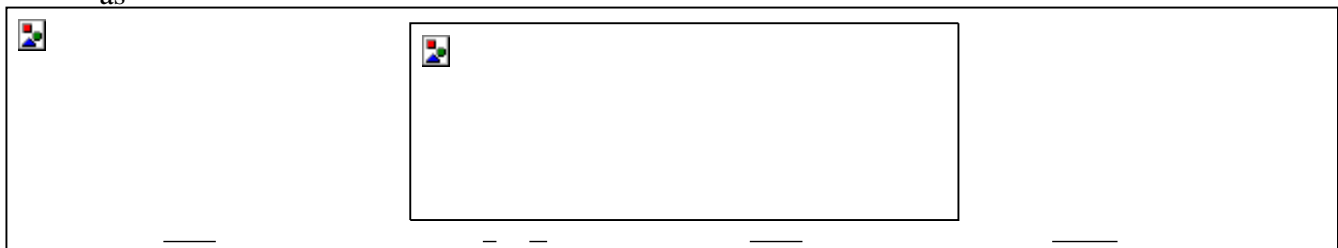

- (1) $\overline{A \cdot B} + A \cdot \overline{B}$
- (2) $A \cdot \overline{B} + \overline{A} \cdot B$
- (3) $\overline{A \cdot B}$
- (4) $\overline{A + B}$

Sol. (2)

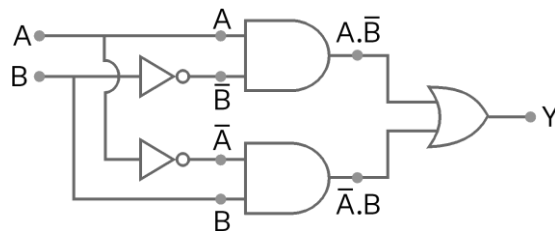

$$Y = (A \cdot \overline{B} + \overline{A} \cdot B)$$

Topic – Electromagnetism

Concept – EM wave

Subject Concept – Propagation of EM wave

Concept Field – Representation of electric and magnetic field associated with EM wave

Question Level – Easy

Expected time to solve – 40 sec

18. An em wave is propagating in a medium with a velocity $\vec{V} = V \hat{i}$. The instantaneous oscillating electric field of this em wave is along +y axis. Then the direction of oscillating magnetic field of the em wave will be along

- (1) -y direction (2) +z direction
 (3) -z direction (4) -x direction

Sol. (2)

$$\vec{E} \times \vec{B} = \vec{V} \Rightarrow (\hat{E} \hat{j}) \times (\hat{B}) = V \hat{i}$$

So, $\vec{B} = B \hat{k}$

Direction of propagation is along +z direction.

Topic – Optics

Concept – Ray optics

Subject Concept – Refraction



Concept Field – Snell's law

Question Level – Moderate

Expected time to solve – 45 sec

19. The refractive index of the material of a prism is $\sqrt{2}$ and the angle of the prism is 30° . of the two refracting surfaces of the prism is made a mirror inwards, by silver coating. A beam of monochromatic light entering the prism from the other face will retrace its path (after reflection from the silvered surface) if its angle of incidence on the prism is

- (1) 30° (2) 45°
 (3) 60° (4) Zero

Sol. (2)

For retracing its path, light ray should be normally incident on silvered face.

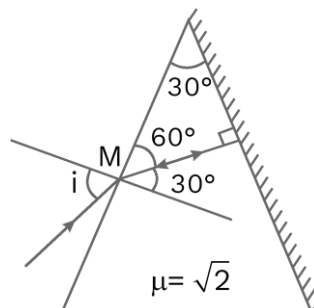

Applying Snell's law at M,

$$\frac{\sin i}{\sin 30^\circ} = \frac{\sqrt{2}}{1} \Rightarrow \sin i = \boxed{2} \times \frac{1}{2}$$

$$\sin i = \boxed{2} \text{ i.e. } i = 45^\circ$$

Topic – Optics

Concept – Ray optics

Subject Concept – Concave mirror

Concept Field – Image formation

Question Level – Moderate

Expected time to solve – 65 sec

20. An object is placed at a distance of 40 cm from a concave mirror of focal length 15 cm. If the object is displaced through a distance of 20 cm towards the mirror, the displacement of the image will be

(1) 30 cm towards the mirror (2) 36 cm away from the mirror

(3) 30 cm away from the mirror (4) 36 cm towards the mirror

Sol.

(2)

$$\frac{1}{f} = \frac{1}{v_1} + \frac{1}{u} \Rightarrow \frac{1}{-15} = \frac{1}{v_1} - \frac{1}{40}$$

$$\Rightarrow \frac{1}{v_1} = \frac{1}{-15} + \frac{1}{40} \Rightarrow v_1 = -24 \text{ cm}$$

When object is displaced by 20 cm towards mirror.

Now, $u_2 = -20$

$$\frac{1}{f} = \frac{1}{v_2} + \frac{1}{u_2} \Rightarrow \frac{1}{-15} = \frac{1}{v_2} - \frac{1}{20}$$

$$\frac{1}{v_2} = \frac{1}{20} - \frac{1}{15} \Rightarrow v_2 = 60 \text{ cm}$$

So, image shifts away from mirror by $= 60 - 24 = 36$ cm.

Topic – Electromagnetism

Concept – Current electricity

Subject Concept – Inductor

Concept Field – Magnetic potential energy

Question Level – Easy

Expected time to solve – 50 sec

21. The magnetic potential energy stored in a certain inductor is 25 mJ, when the current in the inductor is 60 mA. This inductor is of inductance

- (1) 1.389 H (2) 138.88 H (3) 0.138 H (4) 13.89 H

Sol. (4)

Energy stored in inductor

$$U = \frac{1}{2} LI^2 \quad \Rightarrow \quad 25 \times 10^{-3} = \frac{1}{2} \times L \times (60 \times 10^{-3})^2$$

$$L = \frac{25 \times 2 \times 10^6 \times 10^{-3}}{3600} = \frac{500}{36} = 13.89 \text{ H}$$

Topic – Electromagnetism

Concept – Electric field

Subject Concept – Motion of charge in electric field

Concept Field –

Question Level – Easy

Expected time to solve – 40 sec

22. An electron falls from rest through a vertical distance h in a uniform and vertically upward directed electric field E . The direction of electric field is now reversed, keeping its magnitude the same. A proton is allowed to fall from rest in it through the same vertical distance h . The time of fall of the electron, in comparison to the time of fall of the proton is

- (1) 10 times greater (2) 5 times greater
(3) Smaller (4) Equal

Sol. (3)

$$h = \frac{1}{2} \frac{eE}{m} t^2 \quad \therefore \quad t = \sqrt{\frac{2hm}{eE}}$$

$\therefore t \propto \sqrt{m}$ as 'e' is same for electron and proton.

Electron has smaller mass so it will take smaller time.

Topic – Electrostatics

Concept – Capacitor and capacitance

Subject Concept – Capacitor

Concept Field – Parallel plate capacitor

Question Level – Easy

Expected time to solve – 40 sec

23. The electrostatic force between the metal plates of an isolated parallel plate capacitor C having a charge Q and area A, is
- (1) Proportional to the square root of the distance between the plates
 - (2) Linearly proportional to the distance between the plates
 - (3) Independent of the distance between the plates
 - (4) Inversely proportional to the distance between the plates

Sol.

(3)

For isolated capacitor Q = constant

$$F_{\text{plate}} = \frac{Q^2}{2A\epsilon_0}$$

F is independent of the distance between plates.

Topic – Waves

Concept – Sound waves

Subject Concept – Tuning fork

Concept Field – Frequency

Question Level – Easy

Expected time to solve – 40 sec

24. A tuning fork is used to produce resonance in a glass tube. The length of the air column in this tube can be adjusted by a variable piston. At room temperature of 27°C two successive resonances are produced at 20 cm and 73 cm of column length. If the frequency of the tuning fork is 320 Hz, the velocity of sound in air at 27°C is
- (1) 350 m/s (2) 339 m/s (3) 330 m/s (4) 300 m/s

Sol. (2)

$$v = 2(\nu)[L_2 - L_1] = 2 \times 320[73 - 20] \times 10^{-2} = 339.2 \text{ ms}^{-1} = 339 \text{ m / s}$$

Topic – Mechanics

Concept – SHM

Subject Concept – Simple pendulum

Concept Field – Time period

Question Level – Easy

Expected time to solve – 40 sec

25. A pendulum is hung from the roof of a sufficiently high building and is moving freely to and fro like a simple harmonic oscillator. The acceleration of the bob of the pendulum is 20 m/s^2 at a distance of 5 m from the mean position. The time period of oscillation is
- (1) 2 s (2) π s (3) 2π s (4) 1 s

Sol. (2)

$$|a| = \omega^2 y$$

$$\Rightarrow 20 = \omega^2(5) \quad \Rightarrow \omega = 2 \text{ rad/s}$$

$$T = \frac{2\pi}{\omega} = \frac{2\pi}{2} = \pi \text{ s}$$



Topic – Electromagnetism

Concept – Magnetic field and magnetic force

Subject Concept – Magnetic induction

Concept Field – Equilibrium of magnetic force

Question Level – Easy

Expected time to solve – 45 sec

26. A metallic rod of mass per unit length 0.5 kg m^{-1} is lying horizontally on a smooth inclined plane which makes an angle of 30° with the horizontal. The rod is not allowed to slide down by flowing a current through it when a magnetic field of induction 0.25 T is acting on it in the vertical direction. The current flowing in the rod to keep it stationary is
- (1) 14.76 A (2) 5.98 A (3) 7.14 A (4) 11.32 A

Sol. (4)

For equilibrium,

$$mg \sin 30^\circ = lB \cos 30^\circ$$

$$l = \frac{mg}{lB} \tan 30^\circ = \frac{0.5 \times 9.8}{0.25 \times \sqrt{3}} = 11.32 \text{ A}$$

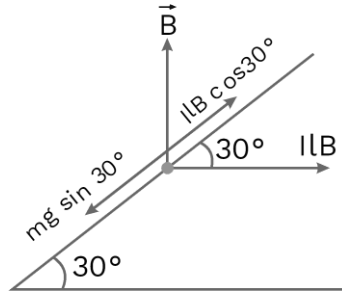

Topic – Electromagnetism

Concept – Magnetic force and magnetic field

Subject Concept – magnetic substances

Concept Field – Potential energy

Question Level – Easy

Expected time to solve – 40 sec

27. A thin diamagnetic rod is placed vertically between the poles of an electromagnet. When the current in the electromagnet is switched on, then the diamagnetic rod is pushed up, out of the horizontal magnetic field. Hence the rod gains gravitational potential energy. The work required to do this comes from
- (1) The lattice structure of the material of the rod
 - (2) The magnetic field
 - (3) The current source
 - (4) The induced electric field due the changing magnetic field

Sol. (3)

Energy of current source will be converted into potential energy of the rod.

Topic – Electromagnetism

Concept – Current electricity

Subject Concept – RLC circuit

Concept Field – Power loss

Question Level – Easy

Expected time to solve – 40 sec

28. An inductor 20 mH, a capacitor 100 μF and a resistor 50 Ω are connected in series across a source of emf, $V = 10 \sin 314 t$. The power loss in the circuit is

- (1) 2.74 W (2) 0.43 W (3) 0.79 W (4) 1.13 W

Sol. (3)

$$P_{av} = \left(\frac{V_{RMS}}{Z} \right)^2 R, \quad Z = \sqrt{R^2 + \left(\omega L - \frac{1}{\omega C} \right)^2} = 56 \Omega$$

$$= \left(\frac{10}{56} \right)^2 \times 50 = 0.79 \text{ W}$$

$$\therefore P_{av} = \left(\frac{10}{\sqrt{2} \cdot 56} \right)^2 \times 50 = 0.79 \text{ W}$$

Topic – Electromagnetism

Concept – Current electricity

Subject Concept – Measuring instrument

Concept Field – Galvanometer

Question Level – Easy

Expected time to solve – 40 sec

29. Current sensitivity of a moving coil galvanometer is 5 div/mA and its voltage sensitivity (angular deflection per unit voltage applied) is 20 div/V. The resistance of the galvanometer is



- (1) 250 Ω (2) 25 Ω (3) 40 Ω (4) 500 Ω

Sol. (1)

$$\text{Current sensitivity, } I_s = \frac{NBA}{C}$$

$$\text{Voltage sensitivity, } V_s = \frac{NBA}{CR_G}$$

So, resistance of galvanometer

$$R_G = \frac{I_s}{V_s} = \frac{5 \times 1}{20 \times 10^{-3}} = \frac{5000}{20} = 250 \Omega$$

Topic – Mechanics

Concept – Laws of motion and friction

Subject Concept – Rolling motion

Concept Field – Conservation of energy

Question Level – Easy

Expected time to solve – 40 sec

30. A body initially at rest and sliding along a frictionless track from a height h (as shown in the figure) just completes a vertical circle of diameter AB = D. The height h is equal to

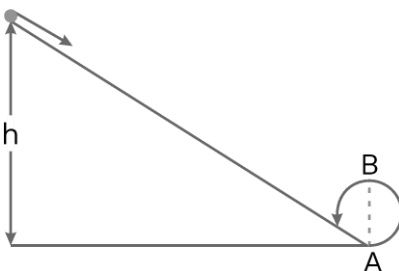

(1) $\frac{7}{5}D$

(2) D

(3) $\frac{3}{2}D$

(4) $\frac{5}{4}D$

Sol. (4)

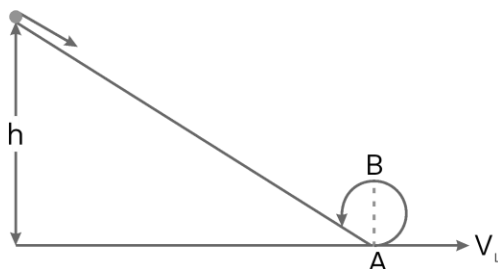

As track is frictionless, so total mechanical energy will remain constant



$$T.M.E_I = T.M.E_F$$

$$0 + mgh = \frac{1}{2}mv_L^2 + 0 \Rightarrow h = \frac{v_L^2}{2g}$$

For completing the vertical circle,

$$v_L \geq \sqrt{5gR} \Rightarrow h = \frac{5gR}{2g} = \frac{5}{2}R = \frac{5}{4}D$$

Topic – Mechanics

Concept – Rotational motion

Subject Concept – Angular speed

Concept Field – Kinetic energy

Question Level – Easy

Expected time to solve – 40 sec

31. Three objects, A: (a solid sphere), B: (a thin circular disk) and C: (a circular ring), each have the same mass M and radius R . They all spin with the same angular speed ω about their own symmetry axes. The amounts of work (W) required to bring them to rest, would satisfy the relation
 (1) $W_B > W_A > W_C$ (2) $W_A > W_B > W_C$ (3) $W_C > W_B > W_A$ (4) $W_A > W_C > W_B$

Sol. (3)

Work done required to bring them rest

$$\Delta W = \Delta KE \quad \Rightarrow \quad \Delta W = \frac{1}{2} I \omega^2$$

$\Delta W \propto I$ for same ω

$$W_A : W_B : W_C = \frac{1}{5} MR^2 : \frac{1}{2} MR^2 : MR^2$$

$$= \frac{2}{5} : 1 : 1 = 4 : 5 : 10$$

$$\Rightarrow W_C > W_B > W_A$$

Topic – Mechanics

Concept – Rotational motion

Subject Concept – Collision

Concept Field – Coefficient of restitution

Question Level – Easy

Expected time to solve – 40 sec

32. A moving block having mass m , collides with another stationary block having mass $4m$. The lighter block comes to rest after collision. When the initial velocity of the lighter block is v , then the value



of coefficient of restitution (e) will be

(1) 0.8

(2) 0.25

(3) 0.5

(4) 0.4

Sol.

(2)

According to law of conservation of linear momentum,

$$mv + 4m \times 0 = 4mv' + 0 \quad \Rightarrow \quad v' = \frac{v}{4}$$

$$e = \frac{\text{Relative velocity of separation}}{\text{Relative velocity of approach}} = \frac{v}{4}$$

$$e = \frac{1}{4} = 0.25$$

Topic – Mechanics

Concept – Laws of motion and friction

Subject Concept – Friction

Concept Field – Sliding friction

Question Level – Easy

Expected time to solve – 40 sec

33. Which one of the following statements is incorrect?

(1) Frictional force opposes the relative motion.

- (2) Limiting value of static friction is directly proportional to normal reaction.
 (3) Rolling friction is smaller than sliding friction.
 (4) Coefficient of sliding friction has dimensions of length.

Sol.

(4)

Coefficient of sliding friction has no dimension.

$$f = \mu_s N \quad \Rightarrow \quad \mu_s = \frac{f}{N}$$

Topic – Mechanics

Concept – Motion in straight line

Subject Concept – Distance and displacement

Concept Field – Average velocity

Question Level – Moderate

Expected time to solve – 80 sec

34. A toy car with charge q moves on a frictionless horizontal plane surface under the influence of a uniform electric field \vec{E} . Due to the force $q\vec{E}$, its velocity increases from 0 to 6 m/s in one second duration. At that instant the direction of the field is reversed. The car continues to move for two more seconds under the influence of this field. The average velocity and the average speed of the toy car between 0 to 3 are respectively
 (1) 1 m/s, 3.5 m/s (2) 1 m/s, 3 m/s (3) 2 m/s, 4 m/s (4) 1.5 m/s, 3 m/s

Sol. (2)

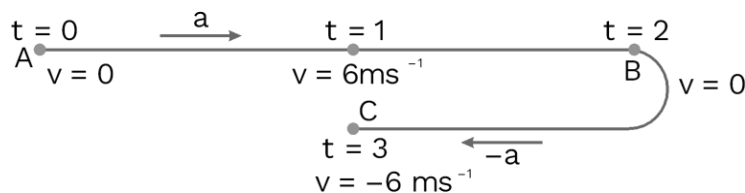

$$\text{Acceleration } a = \frac{6-0}{1} = 6\text{ms}^{-2}$$

For $t = 0$ to $t = 1$ se,

$$S_1 = \frac{1}{2} \times 6(1)^2 = 3\text{m} \quad \dots(\text{i})$$

For $t = 1$ s to $t = 2$ s,

$$S_2 = 6.1 - \frac{1}{2} \times 6(1)^2 = 3\text{m} \quad \dots(\text{ii})$$

For $t = 2$ s to $t = 3$ s,

$$S_3 = 0 - \frac{1}{2} \times 6(1)^2 = -3\text{m} \quad \dots(\text{iii})$$

Total displacement $S = S_1 + S_2 + S_3 = 3 \text{ m}$

$$\text{Average velocity} = \frac{3}{3} = 1\text{ms}^{-1}$$

Total distance travelled = 9 m,

$$\text{Average speed} = \frac{9}{3} = 3 \text{ ms}^{-1}$$

Topic – Mechanics

Concept – Motion on inclined plane

Subject Concept – Wedge constraints

Concept Field – Acceleration

Question Level – Easy

Expected time to solve – 40 sec

35. A block of mass m is placed on a smooth inclined wedge ABC of inclination θ as shown in the figure. The wedge is given an acceleration 'a' towards the right. The relation between a and θ for the block to remain stationary on the wedge is

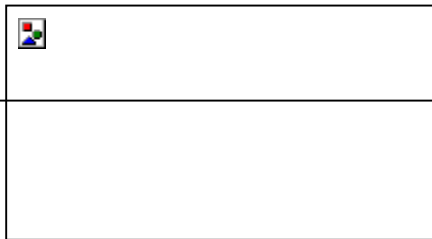

- (1) $a = g \cos \theta$ (2) $a = \frac{g}{\sin \theta}$ (3) $a = \frac{g}{\operatorname{cosec} \theta}$ (4) $a = g \tan \theta$

Sol. (4)

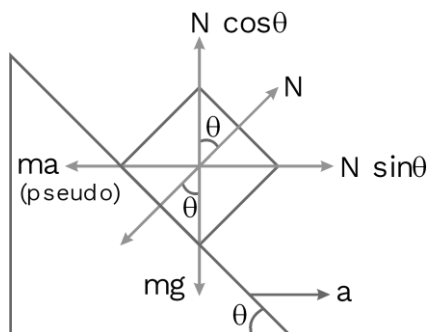

In non-inertial frame,

$$N \sin \theta = ma \quad \dots(\text{i})$$

$$N \cos \theta = mg \quad \dots(\text{ii})$$

$$\tan \theta = \frac{a}{g} \quad \Rightarrow a = g \tan \theta$$

Topic – Mechanics

Concept – Moment of inertia

Subject Concept – Moment of force

Concept Field – torque

Question Level – Easy

Expected time to solve – 40 sec

36. The moment of the force, $\vec{F} = 4\hat{i} + 5\hat{j} - 6\hat{k}$ at $(2, 0, -3)$, about the point $(2, -2, -2)$, is given by
 (1) $-7\hat{i} - 8\hat{j} - 4\hat{k}$ (2) $-4\hat{i} - \hat{j} - 8\hat{k}$ (3) $-8\hat{i} - 4\hat{j} - 7\hat{k}$ (4) $-7\hat{i} - 4\hat{j} - 8\hat{k}$

Sol. (4)

--	--	--

$$\vec{\tau} = (\vec{r} - \vec{r}_0) \times \vec{F} = \dots(\text{i})$$

$$\vec{r} - \vec{r}_0 = (2\hat{i} + 0\hat{j} - 3\hat{k}) - (2\hat{i} - 2\hat{j} - 2\hat{k})$$

$$= 0\hat{i} + 2\hat{j} - \hat{k}$$

$$\vec{\tau} = \begin{vmatrix} \hat{i} & \hat{j} & \hat{k} \\ 0 & 2 & -1 \\ 4 & 5 & -6 \end{vmatrix} = -7\hat{i} - 4\hat{j} - 8\hat{k}$$

Topic – Basics and laboratory

Concept – Least count analysis

Subject Concept – Screw gauge

Concept Field – Zero error

Question Level – Easy

Expected time to solve – 40 sec

37. A student measured the diameter of a small steel ball using a screw gauge of least count 0.001 cm. The main scale reading is 5 mm and zero of circular scale division coincides with 25 divisions above the reference level. If screw gauge has a zero error of the correct diameter of the ball is
(1) 0.053 cm (2) 0.525 cm (3) 0.521 cm (4) 0.529 cm–0.004 cm,

Sol. (4)

Diameter of the ball

$$\begin{aligned} &= \text{MSR} + \text{CSR} \times (\text{Least count}) - \text{Zero error} \\ &= 0.5 \text{ cm} + 25 \times 0.001 - (-0.004) = 0.5 + 0.025 + 0.004 \\ &= 0.529 \text{ cm} \end{aligned}$$

Topic – Mechanics

Concept – Rotational motion

Subject Concept – Solid sphere

Concept Field – Angular momentum

Question Level – Easy

Expected time to solve – 40 sec

38. A solid sphere is rotating freely about its symmetry axis in free space. The radius of the sphere is increased keeping its mass same. Which of the following physical quantities would remain constant for the sphere?
(1) Rotational kinetic energy (2) Moment of inertia
(3) Angular velocity (4) Angular momentum

Sol. (4)

$$\tau_{\text{ex}} = 0 \quad \text{So, } \frac{dL}{dt} = 0$$

i.e. $L = \text{constant}$

So angular momentum remains constant.

Topic – Gravitation

Concept – Gravitation field

Subject Concept – Kinetic energy

Concept Field – Orbit around a sun

Question Level – Easy

Expected time to solve – 40 sec

39. The kinetic energies of a planet in an elliptical orbit about the Sun, at positions A, B and C are K_A , K_B and K_C respectively. AC is the major axis and SB is perpendicular to AC at the position of the Sun S as shown in the figure. Then

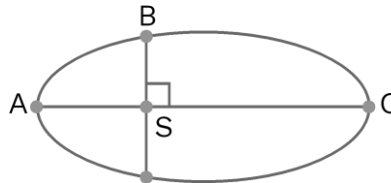

- (1) $K_B < K_A < K_C$ (2) $K_A < K_B < K_C$ (3) $K_A < K_B < K_C$ (4) $K_B > K_A > K_C$

Sol. (2)



Point A is perihelion and C is aphelion.

So, $V_A > V_B > V_C$

So,

$K_A > K_B > K_C$

Topic – Gravitation

Concept – Gravitation field

Subject Concept – Universal gravitational constant

Concept Field – Gravity on earth

Question Level – Easy

Expected time to solve – 40 sec

40. If the mass of the Sun were ten times smaller and the universal gravitational constant were ten times larger in magnitude, which of the following is not correct?
- (1) Time period of a simple pendulum on the Earth would decrease
(2) Walking on the ground would become more difficult
(3) Raindrops will fall faster
(4) 'g' on the Earth will not change

Sol. (4)

If Universal Gravitational constant becomes ten times, then $G' = 10 G$.

So, acceleration due to gravity increases.

i.e. (4) is wrong option.

Topic – Mechanics

Concept – Rotational motion

Subject Concept – Solid sphere

Concept Field – Rotational kinetic energy

Question Level – Easy

Expected time to solve – 40 sec

41. A solid sphere is in rolling motion. In rolling motion a body possesses translational kinetic energy (K_t) as well as rotational kinetic energy (K_r) simultaneously. The ratio $K_t : (K_t + K_r)$ for the sphere is

(1) 10 : 7 (2) 5 : 7 (3) 7 : 10 (4) 2 : 5

Sol. (2)

$$K_t = \frac{1}{2}mv^2$$
$$\Rightarrow K_t + K_r = \frac{1}{2}mv^2 + \frac{1}{2}I\omega^2 = \frac{1}{2}mv^2 + \frac{1}{2}\left(\frac{2}{5}mr^2\right)\left(\frac{v}{r}\right)^2 = \frac{7}{10}mv^2$$
$$\text{So, } \frac{K_t}{K_t + K_r} = \frac{5}{7}$$

Topic – Solid and fluid mechanics

Concept – Fluid mechanics

Subject Concept – Viscosity

Concept Field – Terminal velocity

Question Level – Easy

Expected time to solve – 40 sec

42. A small sphere of radius 'r' falls from rest in a viscous liquid. As a result, heat is produced due to viscous force. The rate of production of heat when the sphere attains its terminal velocity, is proportional to

(1) r^5 (2) r^2 (3) r^3 (4) r^4

Sol. (1)

$$\text{Power} = \text{Force} \cdot \text{Velocity} = 6\pi\eta rV_T \cdot V_T = 6\pi\eta V_T^2$$

$$V_T \propto r^2 \quad \Rightarrow \quad \text{Power} \propto r^5$$

Topic – Dual nature of radiation and matter

Concept – Radiation

Subject Concept – Wavelength

Concept Field – Power radiation

Question Level – Easy

Expected time to solve – 40 sec

43. The power radiated by a black body is P and it radiates maximum energy at wavelength, λ_0 . If the of the black body is now changed so that it radiates maximum energy at wavelength $\frac{3}{4} \lambda_0$, the power radiated by it becomes nP . The value of n is

- (1) $\frac{256}{81}$ (2) $\frac{4}{3}$ (3) $\frac{3}{4}$ (4) $\frac{81}{256}$

Sol.

(1)

We know,

$$\lambda_{\text{max}} T = \text{constant (Wien's law)}$$

$$\text{So, } \lambda_{\text{max}_1} T_1 = \lambda_{\text{max}_2} T_2$$

$$\Rightarrow \lambda_0 T = \frac{3\lambda_0}{4} T' \quad \Rightarrow \quad T' = \frac{4}{3} T \quad \text{So, } \frac{P_2}{P_1} = \left(\frac{T'}{T}\right)^4 = \left(\frac{4}{3}\right)^4 = \frac{256}{81}$$

Topic – Solid and fluid mechanics

Concept – Solids

Subject Concept – Elasticity

Concept Field –

Question Level – Easy

Expected time to solve – 40 sec

44. Two wires are made of the same material and have the same volume. The first wire has cross-sectional area A and the second wire has cross-sectional area $3A$. If the length of the first wire is increased by Δl on applying a force F , how much force is needed to stretch the second wire by the same amount?

(1) $4F$

(2) $6F$

(3) $9F$

(4) F

Sol. (3)

Wire 1 :



Wire 2 :



For wire 1,

$$\Delta l = \left(\frac{F}{AY} \right) 3l \quad \dots(i)$$

For wire 2,

$$\frac{F'}{3A} = Y \frac{\Delta l}{l}$$
$$\Rightarrow \Delta l = \left(\frac{F'}{3AY} \right) l \quad \dots(ii)$$

From equation (i) and (ii),

$$\Delta l = \left(\frac{F}{AY} \right) 3l = \left(\frac{F'}{3AY} \right) l$$

$$\Rightarrow F' = 9F$$

Topic – Thermal physics

Concept – Mode of heat transfer

Subject Concept – FLOT

Concept Field – Internal energy

Question Level – Easy

Expected time to solve – 40 sec

45. A sample of 0.1 g of water at 100°C and normal pressure ($1.013 \times 10^5 \text{ Nm}^{-2}$) requires 54 cal of heat energy to convert to steam at 100°C . If the volume of the steam produced is 167.1 cc, the change in internal energy of the sample, is

(1) 42.2 J

(2) 208.7 J

(3) 104.3 J

(4) 84.5 J

Sol. (2)

$$\Delta Q = \Delta U + \Delta W$$

$$\Rightarrow 54 \times 4.18 = \Delta U + 1.013 \times 10^5 (167.1 \times 10^{-6} - 0)$$

$$\Rightarrow \Delta U = 208.7 \text{ J}$$

Chemistry - 2018

Question Type: NEET

Difficulty of question: Moderate

Expected time to solve: 45 sec.

Topic: Physical chemistry

Concept: Titration (Solution)

1. Following solution were prepared by mixing different volumes of NaOH and HCl of different concentrations:

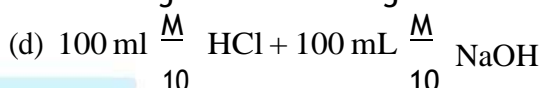
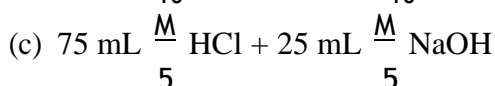
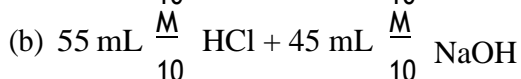
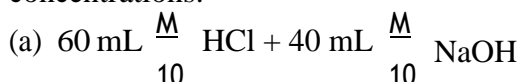

pH of which one of them will be equal to 1?

(1) d

(2) a

(3) b

(4) c

Sol.

$$N_f = \frac{N_1V_1 - N_2V_2}{V_1 + V_2} = \frac{75 \times \frac{1}{5} - 25 \times \frac{1}{5}}{100}$$

$$N_f = 0.1$$

$$\begin{aligned} \therefore \text{pH} &= \log [\text{H}^+] \\ &= -\log 0.1 \\ &= 1 \end{aligned}$$

Question Type: NEET

Difficulty of question: Easy

Expected time to solve: 30 sec.

Topic: Inorganic chemistry

Concept: Surface chemistry

2. On which of the following properties does the coagulating power of an ion depend?

(1) Both magnitude and sign of the charge on the ion

(2) Size of the ion alone

(3) The magnitude of the charge on the ion alone

(4) The sign of charge on the ion alone

Sol. (3)

Coagulating power of an ion depends on the magnitude of the charge on the ion alone.

Question Type: NEET

Difficulty of question: Moderate

Expected time to solve: 30 sec.

Topic: Physical chemistry

Concept: Solubility product (Ionic equilibrium)

3. The solubility of BaSO_4 in water is $2.42 \times 10^{-3} \text{ gL}^{-1}$ at 298 K. The value of its solubility product (K_{sp}) will be

(Given molar mass of $\text{BaSO}_4 = 233 \text{ g mol}^{-1}$)

(1) $1.08 \times 10^{-14} \text{ mol}^2 \text{ L}^{-2}$

(2) $1.08 \times 10^{-12} \text{ mol}^2 \text{ L}^{-2}$

(3) $1.08 \times 10^{-10} \text{ mol}^2 \text{ L}^{-2}$

(4) $1.08 \times 10^{-8} \text{ mol}^2 \text{ L}^{-2}$

Sol. (3)

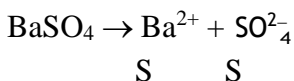

$$K_{\text{sp}} = S^2$$

$$= \left(\frac{2.42 \times 10^{-3}}{233} \right)^2 = 1.08 \times 10^{-10} \text{ mol}^2 / \text{lit}^2$$

Question Type: NEET

Difficulty of question : Easy

Expected time to solve : 20 sec.

Topic : Physical chemistry

Concept: Liquification of gases

4. Given vander Waals constant for NH_3 , H_2 , O_2 and CO_2 are respectively 4.17, 0.244, 1.36 and 3.59, which one of the following gases is most easily liquefied?

(1) O_2

(2) H_2

(3) NH_3

(4) CO_2

Sol. (3)

Ease of liquification depends on a van der waals constants.

Critical temperature \propto Van der walls constant (a)

Maximum a \Rightarrow gas with maximum $T_c \Rightarrow$ easiest liquification = NH_3

Question Type: NEET

Difficulty of question: Moderate

Expected time to solve: 25 sec.

Topic: Organic chemistry

Concept: Phenol

5. In the reaction

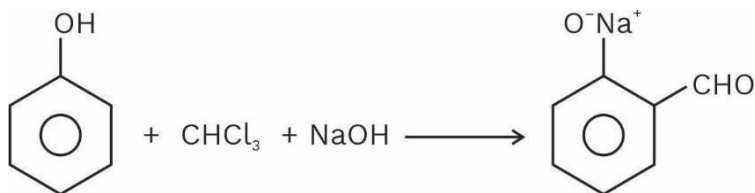

the electrophile involved is

- (1) dichloromethyl anion ($\ominus\text{CHCl}_2$) (2) formyl cation ($\oplus\text{CHO}$)
(3) dichloromethyl cation ($\oplus\text{CHCl}_2$) (4) dichlorocarbene ($:\text{CCl}_2$)

Sol. (4)

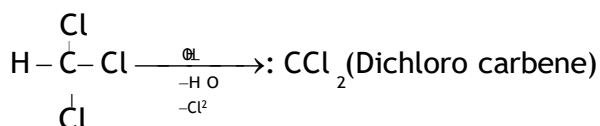

Question Type: NEET

Difficulty of question: Moderate

Expected time to solve: 25 sec.

Topic: Organic chemistry

Concept: Boiling point

6. Carboxylic acids have higher boiling points than aldehydes, ketones and even alcohols of comparable molecular mass. It is due to their

- (1) more extensive association of carboxylic acid via van der Waals force of attraction
(2) formation of carboxylate ion
(3) formation of intramolecular H-bonding
(4) formation of intermolecular H-bonding

Sol. (4)

Carboxylic acids have higher boiling point, because of formation of intermolecular H-bonding.

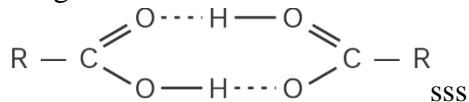

Question Type: NEET

Difficulty of question: Moderate

Expected time to solve: 25 sec.

Topic: Organic chemistry

Concept: Haloform reaction

7. Compound A, $C_8H_{10}O$, is found to react with NaOI (produced by reacting Y with NaOH) and yields a yellow precipitate with characteristic smell. A and Y are respectively

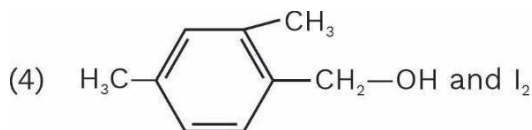
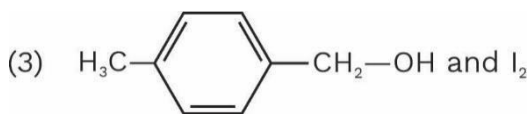
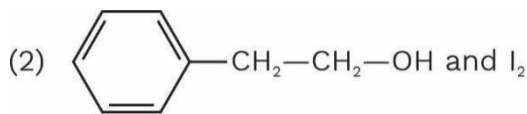
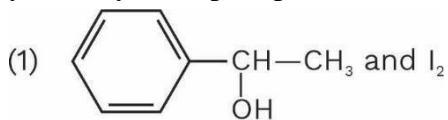

Sol. (1)

Haloform reaction

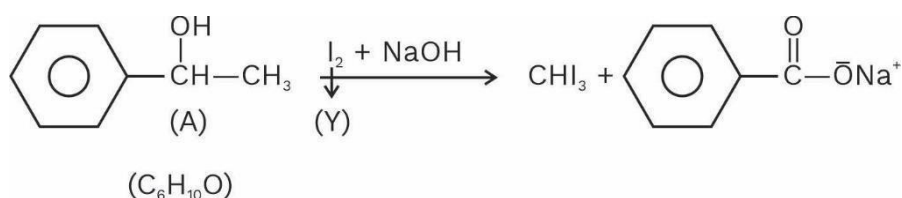

Question Type: NEET

Difficulty of question : Easy

Expected time to solve : 20 sec.

Topic : Inorganic chemistry

Concept : Formula of the compound (Ionic compound)

8. Magnesium reacts with an element (X) to form an ionic compound. If the ground state electronic configuration of (X) is $1s^2 2s^2 2p^3$, the simplest formula for this compound is



Sol. (4)

valency factor for Mg = 2

valency factor for x = 5 thus formula of comp = M_3X_2

Question Type: NEET

Difficulty of question : Moderate

Expected time to solve : 30 sec.

Topic : Physical chemistry

Concept : Density (Solid state)

9. Iron exhibits bcc structure at room temperature. Above 900°C , it transforms to fcc structure. The ratio of density of iron at room temperature to that at 900°C (assuming molar mass and atomic radii of iron remains constant with temperature) is

(1) $\frac{3\sqrt{3}}{4\sqrt{2}}$

(2) $\frac{4\sqrt{3}}{3\sqrt{2}}$

(3) $\frac{3}{2}$

(4) $\frac{1}{2}$

Sol. (1)

bcc $\xrightarrow{\hspace{10em}}$ fcc
 room temp. $\hspace{10em}$ (900°C)
 $Z = 2$ $\hspace{10em}$ $Z = 4$

$$\frac{d_{\text{bcc}}}{d_{\text{fcc}}} = \frac{\frac{Z \times MM}{N_A \times a^3}}{\frac{Z \times MM}{N_A \times a^3}} = \frac{\frac{2}{(4r/\sqrt{3})^3}}{\frac{4}{(4r)^3}}$$

$$\frac{d_{\text{bcc}}}{d_{\text{fcc}}} = \frac{3\sqrt{3}}{4}$$

Question Type: NEET

Difficulty of question : Moderate

Expected time to solve : 25 sec.

Topic : Physical chemistry

Concept : Atomic structure

10. Which one is wrong statement?

(1) The electronic configuration of N atom is

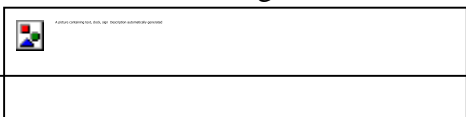

- (2) An orbital is designated by three quantum numbers while an electron in an atom is designated by four quantum numbers.
- (3) Total orbital angular momentum of electron in 's' orbital is equal to zero.
- (4) The value of m for d_z is zero

Sol. (1)

The correct electronic configuration N-atom is

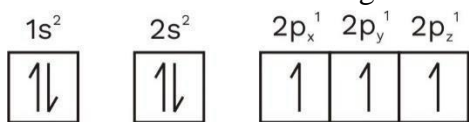

All e^- should be in same spin

Question Type: NEET

Difficulty of question : Moderate

Expected time to solve : 30 sec.

Topic: Inorganic chemistry

Concept: Bond order

11. Consider the following species:

CN⁺, CN⁻, NO and CN

Which one of these will have the highest bond order?

- (1) CN⁺ (2) CN⁻ (3) NO (4) CN

Sol. (2)

$$\text{CN}^+ = \frac{1}{2} (4 - 0) = 2$$

$$\text{NO} = \frac{1}{2} (6 - 1) = 2.5$$

$$\text{CN} = \frac{1}{2} (5 - 0) = 2.5$$

$$\text{CN}^- \text{ total } e^- = 14$$
$$\sigma 1s^2, \sigma^* 1s^2, \sigma 2s^2, \sigma^* 2s^2, \pi 2p_x^2 = \pi 2p_y^2, \sigma 2p_z^2$$

$$\text{BO} = \frac{\text{BMO} - \text{ABMO}}{2} = \frac{10 - 4}{2} = 3$$

Question Type: NEET

Difficulty of question : Moderate

Expected time to solve : 30 sec.

Topic : Inorganic chemistry

Concept : Calculation of lone pair

12. In the structure of ClF₃, the number of lone pairs of electrons on central atom 'Cl' is:

- (1) Four (2) Two (3) One (4) Three

Sol. (2)

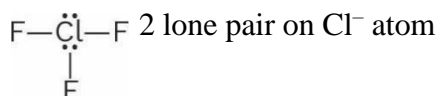

Question Type: NEET

Difficulty of question : Easy

Expected time to solve : 20 sec.

Topic : Inorganic chemistry

Concept : Atomic radius

13. The correct order of atomic radii in group 13 elements is:

- (1) B < Ga < Al < Tl < In (2) B < Al < Ga < In < Tl
(3) B < Al < In < Ga < Tl (4) B < Ga < Al < In < Tl

Sol. (4)

On moving down the group, the atomic radii increases. Due to poor shielding of nuclear charge by

3d e⁻, r_{Ga} < r_{Al}

B < Ga < Al < In < Tl

Question Type: NEET

Difficulty of question : Moderate

Expected time to solve : 25 sec.

Topic : Inorganic chemistry

Concept : Oxidation state

14. The correct order of N-compounds in its decreasing order of oxidation states is:

(1) HNO_3 , NH_4Cl , NO , N_2

(2) HNO_3 , NO , NH_4Cl , N_2

(3) HNO_3 , NO , N_2 , NH_4Cl

(4) NH_4Cl , N_2 , NO , HNO_3

Sol. (3)

$\overset{+5}{\text{HNO}_3}$, $\overset{+2}{\text{NO}}$, $\overset{0}{\text{N}_2}$, $\overset{-3}{\text{NH}_4\text{Cl}}$

Question Type: NEET

Difficulty of question : Easy

Expected time to solve : 20 sec.

Topic : Inorganic chemistry

Concept : Coordination compound

15. Which one of the following elements is unable to form MF_6^{3-} ion?

(1) B

(2) Al

(3) Ga

(4) In

Sol. (1)

Due to absence of vacant d-orbitals, B cannot form BF_6^{3-} ion

Question Type: NEET

Difficulty of question : Easy

Expected time to solve : 25 sec.

Topic : Inorganic chemistry

Concept : Electron gain enthalpy, oxidation state

16. Which of the following statements is *not* true for halogens?

(1) All but fluorine show positive oxidation states

(2) All are oxidizing agents

(3) All form monobasic oxyacids

(4) Chlorine has the highest electron-gain enthalpy

Sol. (1)

F does not show positive oxidation state.

Question Type: NEET

Difficulty of question : Moderate

Expected time to solve : 25 sec.

Topic : Inorganic chemistry
 Concept : Ellingham diagram

17. Considering Ellingham diagram, which of the following metals can be used to reduce alumina?
 (1) Mg (2) Zn (3) Fe (4) Cu

Sol. (1)
 Because graph for ΔG°_f of BeO is below then graph of ΔG°_f of Al_2O_3 in ellingham diagram.

Question Type: NEET
 Difficulty of question : Moderate
 Expected time to solve : 30 sec.
 Topic : Physical chemistry
 Concept : Redox reactions

18. For the redox reaction $MnO_4^- + C_2O_4^{2-} + H^+ \rightarrow Mn^{2+} + CO_2 + H_2O$ the correct coefficients of the reactants for the balanced equation are:

	MnO_4^-	$C_2O_4^{2-}$	H^+
(1)	2	16	5
(2)	2	5	16
(3)	16	5	2
(4)	5	16	2

Sol. (2)
 $MnO_4^- + C_2O_4^{2-} + H^+ \rightarrow Mn^{2+} + CO_2 + H_2O$
 $2MnO_4^- + 5C_2O_4^{2-} + 16H^+ \rightarrow 2Mn^{2+} + 10CO_2 + 8H_2O$

Question Type: NEET
 Difficulty of question : Easy
 Expected time to solve : 20 sec.
 Topic : Physical chemistry
 Concept : Le-Chatelier principle

19. Which one of the following conditions will favour maximum formation of the product in the reaction:

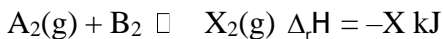

- (1) High temperature and high pressure
 (2) Low temperature and low pressure
 (3) Low temperature and high pressure
 (4) High temperature and low pressure

Sol. (3)

Exothermic reaction has -ve value of $\Delta_r H$.

For exothermic reaction lower temperature favours product

Forward reaction has $\Delta n = 1 - (1 + 1) = -1$, such reaction is favoured at high P.

Question Type: NEET

Difficulty of question : Easy

Expected time to solve : 20 sec.

Topic : Physical chemistry

Concept : Van der Waal's equations (States of matter)

20. The correction factor 'a' to the ideal gas equation corresponds to:

- (1) electric field present between the gas molecules
- (2) volume of the gas molecules
- (3) density of the gas molecules
- (4) forces of attraction between the gas molecules

Sol. (4)

A corresponds to the force of attraction between the gas molecules.



Question Type: NEET

Difficulty of question : Easy

Expected time to solve : 20 sec.

Topic : Physical chemistry

Concept : Half-life (Chemical kinetics)

21. When initial concentration of the reactant is doubled, the half-life period of a zero order reaction:

- (1) is tripled
- (2) is doubled
- (3) is halved
- (4) remains unchanged

Sol. (2)

$$t_{1/2} = \frac{\text{Initial concentration}}{2k}$$

$$t_{1/2} \propto \text{Initial concentration}$$

Question Type : NEET

Difficulty of question : Hard

Expected time to solve : 40 sec.

Topic : Physical chemistry

Concept : Bond dissociation energy (Thermochemistry)

22. The bond dissociation energies of X_2 , Y_2 and XY are in the ratio of 1 : 0.5 : 1. ΔH for the formation of XY is -200 kJ mol^{-1} . The bond dissociation energy of X_2 will be:

- (1) 800 kJ mol^{-1}
- (2) 100 kJ mol^{-1}
- (3) 200 kJ mol^{-1}
- (4) 400 kJ mol^{-1}

Sol. (1)

$$\frac{1}{2}x_2 + \frac{1}{2}y_2 \longrightarrow xy$$

$$\Delta H = \frac{1}{2}E_{\text{rx}} + \frac{1}{2}E_{\text{y-y}} - E_{\text{x-y}} = \Delta H_f(x)$$

$$\Rightarrow \frac{1}{2}a + \frac{0.5}{2}a - a = -200$$

$$\Rightarrow \frac{1}{2}a + \frac{1}{4}a - a = -200$$

$$\Rightarrow \frac{3}{4}a - a = -200$$

$$\Rightarrow -\frac{1}{4}a = -200$$

$$\Rightarrow a = 800 \text{ kJ/mol}$$

Question Type: NEET

Difficulty of question : Moderate

Expected time to solve : 30 sec.

Topic : Inorganic chemistry

Concept : Magnetic moment

23. Match the metal ions given in Column I with the spin magnetic moments of the ions given in Column II and assign the correct code:

Column I		Column II	
a.	Co^{3+}	i.	<input type="checkbox"/> 8 B.M.
b.	Cr^{3+}	ii.	<input type="checkbox"/> $\frac{35}{2}$ B.M.
c.	Fe^{3+}	iii.	<input type="checkbox"/> 3 B.M.
d.	Ni^{2+}	iv.	$\sqrt{24}$ B.M.
		v.	<input type="checkbox"/> $\frac{15}{2}$ B.M.

	a	b	c	d
(1)	iv	i	ii	iii
(2)	i	ii	iii	iv
(3)	iv	v	ii	i
(4)	iii	v	i	ii

Sol.

(3)	Co^{3+}	Cr^{3+}	Fe^{3+}	Ni^{2+}
unpaired	$3d^6$	$3d^3$	$3d^5$	$3d^8$
	4	3	5	2

$$\mu = \sqrt{24} \quad \mu = \sqrt{15} \quad \mu = \sqrt{35} \quad \mu = \sqrt{8}$$

$$\mu = \sqrt{n(n+2)} \text{ BM}$$

Question Type: NEET

Difficulty of question : Moderate

Expected time to solve : 30 sec.

Topic : Inorganic chemistry

Concept : Transition

24. Which one of the following ions exhibits d-d transition and paramagnetism as well?

- (1) MnO_4^- (2) CrO_2^{2-} (3) CrO_4^{2-} (4) MnO_4^{2-}

Sol. (4)



Question Type: NEET

Difficulty of question : Moderate

Expected time to solve : 25 sec.

Topic : Inorganic chemistry

Concept : Geometrical isomerism

25. The type of isomerism shown by the complex $[\text{CoCl}_2(\text{en})_2]$ is

- (1) Ionization isomerism (2) Coordination isomerism
 (3) Geometrical isomerism (4) Linkage isomerism

Sol. (3)



Question Type: NEET

Difficulty of question : Moderate

Expected time to solve : 30 sec.

Topic : Inorganic chemistry

Concept : Isomerism

26. The geometry and magnetic behaviour of the complex $[\text{Ni}(\text{CO})_4]$ are

- (1) square planar geometry and paramagnetic
 (2) tetrahedral geometry and diamagnetic
 (3) square planar geometry and diamagnetic
 (4) tetrahedral geometry and paramagnetic

Sol. (2)



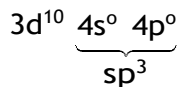

Question Type: NEET

Difficulty of question : Easy

Expected time to solve : 25 sec.

Topic : Inorganic chemistry

Concept : Coordination compounds

27. Iron carbonyl, $Fe(CO)_5$ is
 (1) trinuclear (2) mononuclear (3) tetranuclear (4) dinuclear

Sol. (2)
 $Fe(CO)_5$ Only one central metal atom

Question Type: NEET

Difficulty of question : Moderate

Expected time to solve : 30 sec.

Topic : Physical chemistry

Concept : Order of the reaction (Chemical kinetics)

28. The correct difference between first and second-order reactions is that
 (1) a first-order reaction can be catalyzed; a second-order reaction cannot be catalyzed
 (2) The half-life of a first-order reaction does not depend on $[A]_0$; the half-life of a second-order reaction does depend on $[A]_0$
 (3) The rate of a first-order reaction does not depend on reactant concentrations; the rate of a second order reaction does depend on reactant concentrations
 (4) The rate of a first-order reaction does depend on reactant concentration; the rate of a second order reaction does not depend on reactant concentrations

Sol. (2)
 $t_{1/2} = \frac{0.693}{k}$ (independent of Initial concentration)
 $t_{1/2} = \frac{1}{k \times \text{Initial concentration}}$ (depends on initial concentration)

Question Type: NEET

Difficulty of question : Moderate

Expected time to solve : 25 sec.

Topic : Inorganic chemistry

Concept : Ionic character

29. Among CaH_2 , BeH_2 , BaH_2 , the order of ionic character is
 (1) $\text{BeH}_2 < \text{BaH}_2 < \text{CaH}_2$ (2) $\text{CaH}_2 < \text{BeH}_2 < \text{BaH}_2$
 (3) $\text{BeH}_2 < \text{CaH}_2 < \text{BaH}_2$ (4) $\text{BaH}_2 < \text{BeH}_2 < \text{CaH}_2$

Sol. (3)

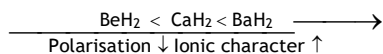

Question Type: NEET

Difficulty of question : Moderate

Expected time to solve : 30 sec.

Topic : Inorganic chemistry

Concept : Oxidation state

30. Consider the change in oxidation state of Bromine corresponding to different emf values as shown in the diagram below:



Which of the following will undergo disproportionation reaction?

- (1) Br_2 (2) BrO_4^- (3) BrO_3^- (4) HBrO

Sol. (4)

As, BrO_4^- is present in its highest oxidation state (+7), so it will not undergo disproportionation, for BrO_3^-

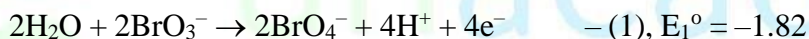

$$\therefore (1) + (2) = (3)$$

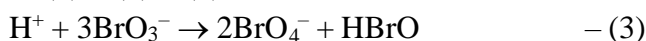

$$E_3^\circ = \frac{-1.82 \times 4 + 1.5 \times 4}{4}$$

$$= -ve$$

Also for HBrO

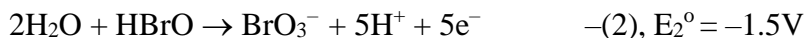
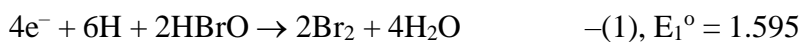

$$(1) + (2) = (3)$$

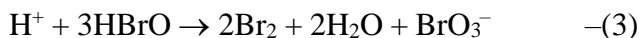

$$\therefore E_3^\circ = \frac{1.595 \times 4 - 1.5 \times 4}{4} = +ve$$

So, HBrO will disproportionate

Question Type: NEET

Difficulty of question : Moderate

Expected time to solve : 35 sec.

Topic : Physical chemistry

Concept : Mole concept

31. In which case the number of molecules of water is maximum?

- (1) 0.00224 L of water vapours at 1 atm and 273 K
- (2) 0.18 g of water
- (3) 18 mL of water
- (4) 10^{-3} mol of water

Sol. (3)

(1) At NTP, 0.00224 L $\frac{1}{22.4}$ = 0.0001 mole

(2) $n = \frac{0.18}{18} = 0.01$ mole

(3) $d_{H_2O} = 1$ gm/ml

$\therefore w = 18$ gm

So, $n = \frac{18}{18} = 1$ mole

(4) 10^{-1} mole

\therefore maximum no. of moles is present in 18 ml of H_2O .

Question Type: NEET

Difficulty of question : Easy

Expected time to solve : 20 sec.

Topic : Organic chemistry

Concept : Hybridisation

32. Which of the following molecules represents the order of hybridisation sp^2 , sp^2 , sp , sp from left to right atoms?

(1) $CH_2=CH-CH=CH_2$

(2) $CH_2=CH-C\equiv CH$

(3) $HC\equiv C-C\equiv CH$

(4) $CH_3-CH=CH-CH_3$

Sol. (2)

$CH_2 = CH - CH \equiv CH$
 $\downarrow \quad \downarrow \quad \downarrow \quad \downarrow$
 $sp^2 \quad sp^2 \quad sp \quad sp$

Question Type: NEET

Difficulty of question : Moderate

Expected time to solve : 30 sec.

Topic : Organic chemistry

Concept : Stability of carbocation

33. Which of the following carbocations is expected to be most stable?

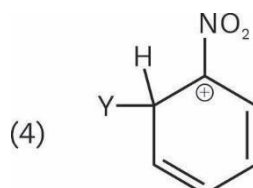
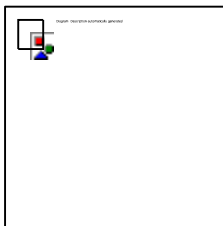
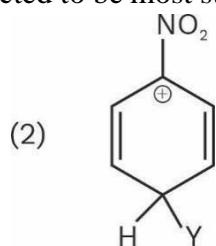
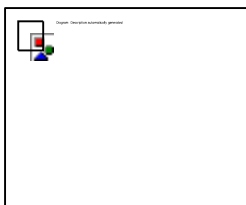

Sol. (1)



Question Type: NEET

Difficulty of question : Easy

Expected time to solve : 25sec.

Topic : Organic chemistry

Concept: Inductive effect

34. Which of the following is correct with respect to $-I$ effect of the substituents?

(R = alkyl)

(1) $-\text{NH}_2 > -\text{OR} > -\text{F}$

(2) $-\text{NR}_2 < -\text{OR} < -\text{F}$

(3) $-\text{NH}_2 < -\text{OR} < -\text{F}$

(4) $-\text{NR}_2 > -\text{OR} > -\text{F}$

Sol. 3

$-\text{NH}_2 < \text{OR} < -\text{F}$ ($-I$ order)

Question Type: NEET

Difficulty of question : Moderate

Expected time to solve : 30 sec.

Topic : Organic chemistry

Concept : Electrophilic substitution reaction

35. Identify the major products P, Q and R in this following sequence of reactions:

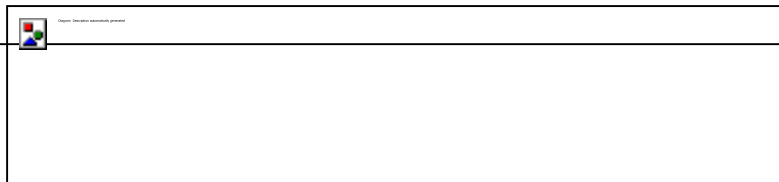
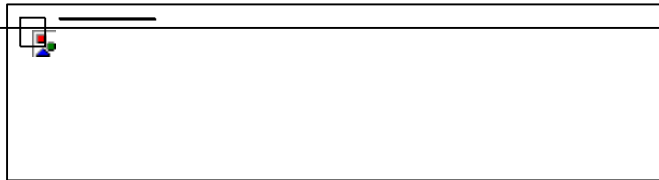
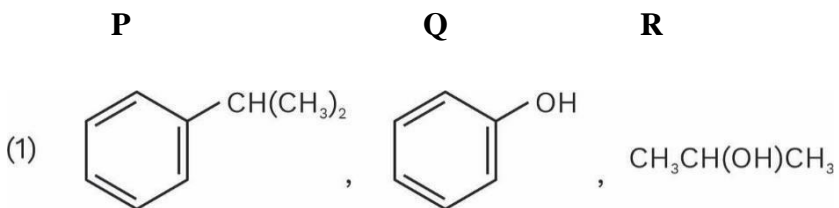
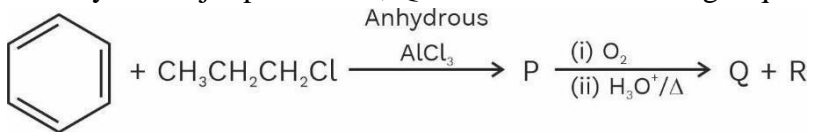

Sol. (4)

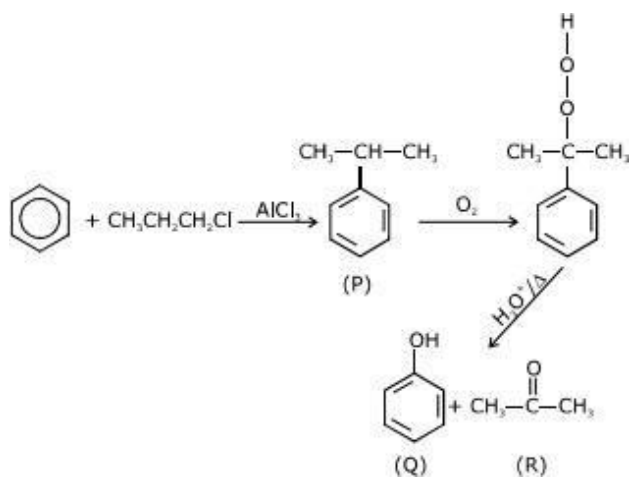

Question Type: NEET

Difficulty of question : Moderate

Expected time to solve : 25 sec.

Topic : Organic chemistry

Concept : Zwitter ion

36. Which of the following compounds can form a zwitter ion ?

- (1) Benzoic acid (2) Acetanilide (3) Aniline (4) Glycine

Sol. (4)

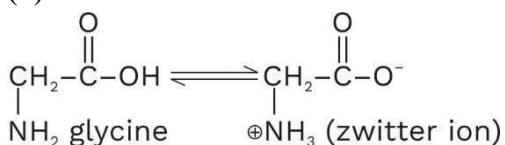

Question Type: NEET

Difficulty of question : Moderate

Expected time to solve : 25 sec.

Topic : Organic chemistry

Concept : Wurtz reaction

37. The compound A on treatment with Na gives B, and with PCl_5 gives C. B and C react together to give diethyl ether. A, B and C are in the order:

- (1) $\text{C}_2\text{H}_5\text{Cl}$, C_2H_6 , $\text{C}_2\text{H}_5\text{OH}$ (2) $\text{C}_2\text{H}_5\text{OH}$, $\text{C}_2\text{H}_5\text{Cl}$, $\text{C}_2\text{H}_5\text{ONa}$
(3) $\text{C}_2\text{H}_5\text{OH}$, C_2H_6 , $\text{C}_2\text{H}_5\text{Cl}$ (4) $\text{C}_2\text{H}_5\text{OH}$, $\text{C}_2\text{H}_5\text{ONa}$, $\text{C}_2\text{H}_5\text{Cl}$

Sol. (4)

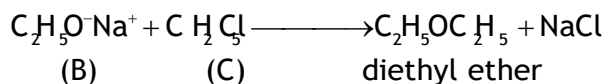
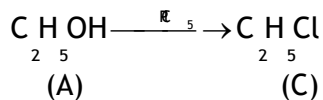
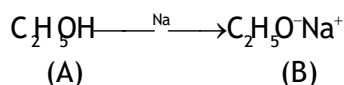

Question Type: NEET

Difficulty of question : Moderate

Expected time to solve : 25 sec.

Topic : Organic chemistry

Concept : Wurtz reaction

38. Hydrocarbon (A) reacts with bromine by substitution to form an alkyl bromide which by Wurtz reaction is converted to gaseous hydrocarbon containing less than four carbon atoms (A) is:

- (1) $\text{CH}_3\text{-CH}_3$ (2) $\text{CH}_2=\text{CH}_2$ (3) $\text{CH}\equiv\text{CH}$ (4) CH_4

Sol. (4)

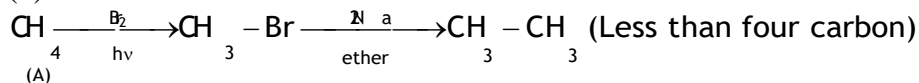

Question Type: NEET

Difficulty of question : Moderate

Expected time to solve : 30 sec.

Topic : Organic chemistry

Concept : Free radical reaction

39. The compound C_7H_8 undergoes the following reactions:

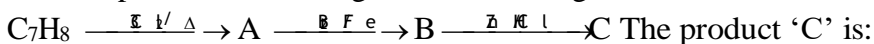

- (1) 3-bromo-2, 4, 6-trichlorotoluene (2) o-bromotoluene

- (3) m-bromotoluene (4) p-bromotoluene

Sol. (3)

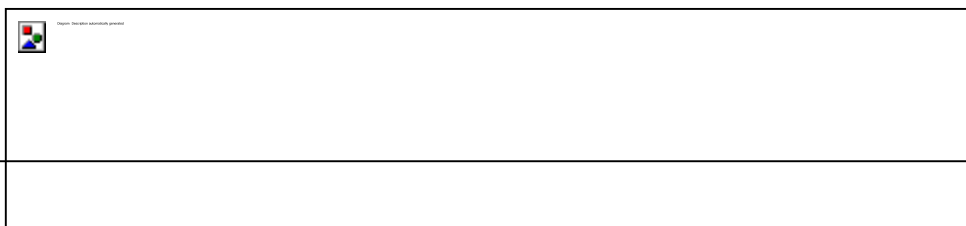

Question Type: NEET

Difficulty of question : Easy

Expected time to solve : 20 sec.

Topic : Organic chemistry

Concept: Environmental chemistry

40. Which oxide of nitrogen is not a common pollutant introduced into the atmosphere both due to natural and human activity?

- (1) N_2O (2) NO_2 (3) N_2O_5 (4) NO

Sol. (3)

N_2O_5 is known as nitrogen peroxide. It doesn't pollute the environment.

Question Type: NEET

Difficulty of question : Easy

Expected time to solve : 20 sec.

Topic : Organic chemistry

Concept : Polymer

41. Regarding cross-linked or network polymers, which of the following statements is incorrect?

- (1) Examples are bakelite and melamine.
- (2) They are formed from bi- and tri-functional monomers.
- (3) They contain covalent bonds between various linear polymer chains.
- (4) They contain strong covalent bonds in their polymer chains.

Sol. (4)

They do not contain strong covalent bonds in their polymer chains.

Question Type: NEET

Difficulty of question : Easy

Expected time to solve : 20 sec.

Topic : Inorganic chemistry

Concept : Oxides

42. Which of the following oxides is most acidic in nature?

- (1) BaO (2) BeO (3) MgO (4) CaO

Sol. 2

Due to polarization, BeO is the most acidic in given oxides.

Question Type: NEET

Difficulty of question : Moderate

Expected time to solve : 25 sec.

Topic : Organic chemistry

Concept : Amines

43. Nitration of aniline in strong acidic medium also gives m-nitroaniline because:

- (1) In absence of substituents nitro group always goes to m-position.
- (2) In electrophilic substitution reactions amino group is meta directive.
- (3) In spite of substituents nitro group always goes to only m-position.
- (4) In acidic (strong) medium aniline is present as anilinium ion.

Sol. (4)

Question Type: NEET

Difficulty of question : Hard

Expected time to solve : 40 sec.

Topic : Physical chemistry

Concept : Mole concept

44. A mixture of 2.3 g formic acid and 4.5 g oxalic acid is treated with conc. H_2SO_4 . The evolved gaseous mixture is passed through KOH pellets. Weight (in g) of the remaining product at STP will be:

- (1) 2.8 (2) 3.0 (3) 1.4 (4) 4.4

Sol. (1)

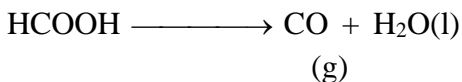

2.3 gm

$$n = \frac{2.3}{46}$$

$$n = \frac{1}{20} \text{ moles} \quad \frac{1}{20} \text{ moles} \quad \frac{1}{20} \text{ moles}$$

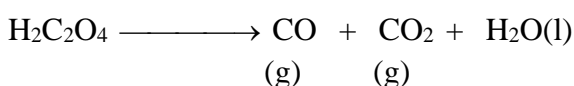

4.5 gm

$$n = \frac{4.5}{90}$$

$$n = \frac{1}{20} \text{ moles} \quad \frac{1}{20} \text{ moles} \quad \frac{1}{20} \text{ moles} \quad \frac{1}{20} \text{ moles}$$

∴ on passing through KOH only
CO will remain as CO_2 is absorbed

$$\therefore n_{\text{CO}} = \frac{1}{20} + \frac{1}{20} \text{ moles}$$

$$w_{\text{CO}} = \frac{1}{10} \times 28$$

$$w_{\text{CO}} = 2.8 \text{ gms.}$$

Question Type: NEET

Difficulty of question : Moderate

Expected time to solve : 25 sec.

Topic : Organic chemistry

Concept : Biomolecules

45. The difference between amylose and amylopectin is:

- (1) Amylopectin have 1 → 4 α-linkage and 1 → 6 β-linkage
 (2) Amylose have 1 → 4 α-linkage and 1 → 6 β-linkage
 (3) Amylopectin have 1 → 4 α-linkage and 1 → 6 α-linkage
 (4) Amylose is made up of glucose and galactose

Sol. (3)

Biology - 2018

Class 12th

Question Type: NEET

Difficulty of question: Moderate

Expected time to solve: 20 secs

Topic: Molecular Basis of Inheritance

Concept: Genetic Material

Sub-concept: Replication of DNA

Concept field: Meselson and Stahl's Experiment

1. The experimental proof for semi-conservative replication of DNA was first shown in a
- (1) Fungus (2) Bacterium (3) Plant (4) Virus

Answer (2)

Sol. The semi-conservative nature of replication of DNA was proved by Meselson and Stahl in an experiment using *E. Coli*.

Class 12th

Question Type: NEET

Difficulty of question: Moderate

Expected time to solve: 25 secs

Topic: Principles of Inheritance

Concept: Mendel's Experiment

Sub-concept: Punnett Square

Concept field: Graphical Representation of Genotypes

2. Select the correct statement:
- (1) Franklin Stahl coined the term "linkage".
(2) Punnett square was developed by a British scientist.
(3) Spliceosomes take part in translation.
(4) Transduction was discovered by S. Altman.

Answer (2)

Sol. Punnett square was developed by a British geneticist, Reginald C. Punnett.

Class 12th

Question Type: NEET

Difficulty of question: Difficult

Expected time to solve: 30 secs

Topic: Reproduction in Organisms

Concept: Asexual Reproduction

Sub-concept: Vegetative Propagules in Angiosperms

Concept field: Offset

3. Offsets are produced by
- (1) Meiotic divisions (2) Mitotic divisions
(3) Parthenocarpy (4) Parthenogenesis

Answer (2)

Sol. Offset is a vegetative propagule which gives rise to new plants that are identical to parent plant. Vegetative parts grow through mitotic divisions.

Class 12th

Question Type: NEET

Difficulty of question: Difficult

Expected time to solve: 30 secs

Topic: Principles of Inheritance and Variation

Concept: Exceptions to Mendel's law of Inheritance

Sub-concept: Linkage and Pleiotropy

Concept field: Pleiotropism

4. Which of the following pairs is wrongly matched?

- (1) Starch synthesis in pea : Multiple alleles
- (2) ABO blood grouping : Co-dominance
- (3) XO type sex determination : Grasshopper
- (4) T.H. Morgan : Linkage

Answer (1)

Sol. Starch synthesis in pea is controlled by one gene and that gene is also responsible for the shape of the seed. It shows pleiotropy.

Class 12th

Question Type: NEET

Difficulty of question: Moderate

Expected time to solve: 20 secs

Topic: Reproduction in Organisms

Concept: Types of Reproduction

Sub-concept: Sexual Reproduction

Concept field: Types of Plants

5. Which of the following flowers only once in its life-time?

- (1) Bamboo species (2) Jackfruit (3) Mango (4) Papaya

Answer (1)

Sol. Bamboo is a plant which can flower only once in its lifetime. Such plants are known as monocarpic plants.

Class 12th

Question Type: NEET

Difficulty of question: Difficult

Expected time to solve: 30 secs

Topic: Molecular Basis of Inheritance

Concept: Expression of Genes

Sub-concept: Regulation of Gene Expression

Concept field: Lac Operon

6. Select the correct match:

- (1) Alec Jeffreys - *Streptococcus pneumoniae*

- (2) Alfred Hershey and Martha Chase - TMV
 (3) Matthew Meselson and F. Stahl - *Pisum sativum*
 (4) Francois Jacob and Jacques Monod - Lac operon

Answer (4)

Sol. François Jacob and Jacques Monod were awarded with Nobel prize in physiology and medicine (1965) for their discoveries regarding the operon.

Class 12th

Question Type: NEET

Difficulty of question: Moderate

Expected time to solve: 30 secs

Topic: Sexual Reproduction in Flowering Plants

Concept: Flower

Sub-concept: Pre fertilization: Structure and Events

Concept field: Pollen Grain

7. Which of the following has proved helpful in preserving pollen as fossils?

- (1) Pollenkitt (2) Cellulosic intine
 (3) Oil content (4) Sporopollenin

Answer (4)

Sol. One of the most resistant biological material found in exine of pollen grains is sporopollenin.

Sporopollenin provides resistant to microbial and chemical de-composition thus pollen grains are preserved during fossilization.

Class 11th

Question Type: NEET

Difficulty of question: Difficult

Expected time to solve: 30 secs

Topic: Transport in Plants

Concept: Long Distance Transport of Water

Sub-concept: Transpiration

Concept field: Opening and Closing of Stomata

8. Stomatal movement is not affected by

- (1) Temperature (2) Light (3) O₂ concentration (4) CO₂ concentration

Answer (3)

Sol. Opening and closing of stomata is affected by light, temperature and concentration of CO₂. It is independent of O₂ concentration.

Class 11th

Question Type: NEET

Difficulty of question: Moderate

Expected time to solve: 30 secs

Topic: Cell Cycle and Cell Division

Concept: Cell Division

Sub-concept: Meiosis I

Concept field: Diplotene

9. The stage during which separation of the paired homologous chromosomes begins is
(1) Pachytene (2) Diplotene (3) Diakinesis (4) Zygotene

Answer (2)

Sol. Diplotene is a sub phase in meiosis I cell division and its beginning is marked by the dissolution of the synaptonemal complex and separation of recombinant homologous chromosomes.

Class 11th

Question Type: NEET

Difficulty of question: Difficult

Expected time to solve: 30 secs

Topic: Biomolecules

Concept: Macromolecules

Sub-concept: Structure of Polysaccharides

Concept field: Sugars

10. The two functional groups characteristic of sugars are
(1) hydroxyl and methyl (2) carbonyl and methyl
(3) carbonyl and phosphate (4) carbonyl and hydroxyl

Answer (4)

Sol. Carbonyl and hydroxyl are the two main functional groups of sugars. Both are basic components of sugars and are found in all sugars.

Class 11th

Question Type: NEET

Difficulty of question: Moderate

Expected time to solve: 20 secs

Topic: Photosynthesis

Concept: Light Reaction

Sub-concept: Electron Transport system

Concept field: Photophosphorylation

11. Which of the following is not a product of light reaction of photosynthesis?
(1) ATP (2) NADH (3) NADPH (4) Oxygen

Answer (2)

Sol. ATP, NADPH and oxygen are products of light reaction, while NADH is a product of Kreb's cycle in respiration process.

Class 11th

Question Type: NEET

Difficulty of question: Moderate

Expected time to solve: 15 secs

Topic: Anatomy of Flowering Plants

Concept: The Tissue System

Sub-concept: Epidermal Tissue System

Concept field: Stomatal Apparatus

12. Stomata in grass leaf are

- (1) Dumb-bell shaped
- (3) Rectangular

- (2) Kidney shaped
- (4) Barrel shaped

Answer (1)

Sol. Stomata in grass leaf (monocots) are dumb-bell shaped whereas in dicot it is kidney shaped.

Class 11th

Question Type: NEET

Difficulty of question: Moderate

Expected time to solve: 20 secs

Topic: Biological classification

Concept: 5 Kingdom Classification

Sub-concept: Eukaryotes and Prokaryotes

Concept field: Examples

13. Which among the following is not a prokaryote?

- (1) *Saccharomyces*
- (3) *Nostoc*

- (2) *Mycobacterium*
- (4) *Oscillatoria*

Answer (1)

Sol. *Saccharomyces*, also called as yeast is a eukaryote (unicellular fungi) whereas *mycobacterium* is a bacterium and *Nostoc* and *Oscillatoria* are blue green algae.

Class 11th

Question Type: NEET

Difficulty of question: Moderate

Expected time to solve: 30 secs

Topic: Cell : The Unit of Life

Concept: Eukaryotic Cell

Sub-concept: Cell Organelles

Concept field: Components of Nucleus

14. Which of the following is true for nucleolus?

- (1) Larger nucleoli are present in dividing cells.
- (2) It is a membrane-bound structure.
- (3) It takes part in spindle formation.
- (4) It is a site for active ribosomal RNA synthesis.

Answer (4)

Sol. Nucleolus is the site for active rRNA (ribosomal RNA) synthesis.

Class 11th

Question Type: NEET

Difficulty of question: Moderate

Expected time to solve: 30 secs

Topic: Cell -The unit of life.

Concept: Eukaryotic cell.

Sub-concept: Cell organelles.

Concept field: Golgi complex and its function.

15. The Golgi complex participates in

- (1) Fatty acid breakdown
(2) Formation of secretory vesicles
(3) Respiration in bacteria
(4) Activation of amino acid

Answer (2)

Sol. Golgi complex helps in glycosylation which involves formation of secretory vesicles and protein transport.

Class 12th

Question Type: NEET

Difficulty of question: Moderate

Expected time to solve: 20 secs

Topic: Environmental Tissue

Concept: Ozone Depletion

Sub-concept: Causes of Ozone Depletion

Concept field: Process of Ozone Depletion

16. In stratosphere, which of the following element acts as a catalyst in degradation of ozone a release of molecular oxygen?

- (1) Carbon (2) Cl (3) Fe (4) Oxygen

Answer (2)

Sol. Ultraviolet rays act on chlorofluorocarbons. (CFCs) to release Cl atoms. Chlorine reacts with ozone in sequential method converting into oxygen. Carbon, oxygen and Fe aren't related to ozone layer depletion.

Class 12th

Question Type: NEET

Difficulty of question: Easy

Expected time to solve: 15 secs

Topic: Environmental Issues

Concept: Air Pollution

Sub-concept: Secondary Pollutants

Concept field: Formation of Secondary Pollutants

17. Which of the following is a secondary pollutant

- (1) CO (2) CO₂ (3) SO₂ (4) O₃

Answer (4)

Sol. Secondary pollutants are pollutants which *form in the atmosphere*. These pollutants are *not* emitted directly from a source (like vehicles or power plants). Instead, they form as a result of the pollutants emitted from these sources reacting with molecules in the atmosphere.

Different types of secondary pollutants include ozone (O₃), sulfuric acid and nitric acid (component of acid rain), particulate matter, nitrogen dioxide (NO₂), peroxyacyl nitrates (PANs).

Class 12th

Question Type: NEET

Difficulty of question: Easy

Expected time to solve: 20 secs

Topic: Organisms and Populations

Concept: Organisms and Populations

Sub-concept: Habitat

Concept field: Niche

18. Niche is

- (1) all the biological factors in the organism environment
- (2) the physical space where an organism live
- (3) the range of temperature that the organism needs to live
- (4) the functional role played by the organism where it lives

Answer (4)

Sol. Each organism has an invariably defined range of conditions that it can tolerate, diversity in the resources it utilises and a distinct functional role in the ecological system, all these together comprise its niche.

Class 12th

Question Type: NEET

Difficulty of question: Easy

Expected time to solve: 15 secs

Topic: Organisms and Populations

Concept: Populations

Sub-concept: Population Attributes

Concept field: Birth rate

19. Natality refers to

- (1) Death rate
- (2) Birth rate
- (3) Number of individuals leaving the habitat
- (4) Number of individuals entering a habitat

Answer (2)

Sol. A population has certain attributes like a population has birth rates and death rates. In a population these rates refer to per capita births and deaths

Class 12th

Question Type: NEET

Difficulty of question: Easy

Expected time to solve: 15 secs

Topic: Ecosystem

Concept: Ecosystem

Sub-concept: Ecological Pyramids

Concept field: Pyramid of Biomass

20. What type of ecological pyramid would obtained with the following data?

Secondary consumer : 120 g

Primary consumer : 60 g

Primary producer : 10 g

- (1) Inverted pyramid of biomass
- (2) Pyramid of energy
- (3) Upright pyramid of numbers
- (4) Upright pyramid of biomass

Answer (1)

Sol. The pyramid of biomass may be "inverted". For example, in a pond ecosystem, the standing crop of phytoplankton, the major producers, at any given point will be lower than the mass of the heterotrophs, such as fish and insects.

Class 12th

Question Type: NEET

Difficulty of question: Easy

Expected time to solve: 15 secs

Topic: Environmental Issues

Concept: Ozone Depletion

Sub-concept: Protection of Ozone Layer

Concept field: Protection of Ozone Layer

21. World Ozone Day is celebrated on

- (1) 5thJune (2) 21stApril (3) 16thSeptember (4) 22ndApril

Answer (3)

Sol. 16 September, In 1985, the world's governments adopted the Vienna Convention for the protection of the ozone layer. Under the Convention's Montreal Protocol, governments, scientists and industry worked together to cut out 99 per cent of all ozone-depleting substances

Class 12th

Question Type: NEET

Difficulty of question: Moderate

Expected time to solve: 30 secs

Topic: Biotechnology : Principles and Processes

Concept: Tools of Recombinant DNA Technology

Sub-concept: Cloning Vectors

Concept field: Cloning Vectors

22. Which of the following is commonly used as a vector for introducing a DNA fragment in human lymphocytes?

- (1) Retrovirus (2) Ti plasmid (3) λ phage (4) pBR 322

Answer (1)

Sol. Retroviruses have also been disarmed and are now used to deliver desirable genes into animal cells. So, once a gene or a DNA fragment has been ligated into a suitable vector it is transferred into a bacterial, plant or animal host (where it multiplies)

Class 12th

Question Type: NEET

Difficulty of question: Moderate

Expected time to solve: 25 secs

Topic: Biotechnology and its Applications

Concept: Ethical Issues

Sub-concept: Validity of GM Research

Concept field: Safety of Introducing GM-organisms for Public Services

23. In India, the organisation responsible for assessing the safety of introducing genetically modified organisms for public use is
- (1) Indian Council of Medical Research (ICMR)
 - (2) Council for Scientific and Industrial Research (CSIR)
 - (3) Research Committee on Genetic Manipulation (RCGM)
 - (4) Genetic Engineering Appraisal Committee (GEAC)

Answer (4)

Sol. Some ethical standards are required to evaluate the morality of all human activities that might help or harm living organisms. Therefore, the Indian Government has set up organisations such as GEAC (Genetic Engineering Approval Committee), which will make decisions regarding the validity of GM research and the safety of introducing GM-organisms for public services.

Class 12th

Question Type: NEET

Difficulty of question: Easy

Expected time to solve: 20 secs

Topic: Biotechnology and its Applications

Concept: Ethical Issues

Sub-concept: Patents

Concept field: Flaws in Patent Rules

24. A new variety of rice was patented by a foreign company though such varieties have been present in India for a long time. This is related to
- (1) Co-667
 - (2) Sharbati Sonora
 - (3) Lerma Rojo
 - (4) Basmati

Answer (4)

Sol. Reference to Basmati in ancient texts, folklore and poetry, has been grown for centuries in India. In 1997, an American company got patent rights on Basmati rice through the US Patent and Trademark Office. This allowed the company to sell a 'new' variety of Basmati, in the US and abroad. This 'new' variety of Basmati had been derived from Indian farmer's varieties.

Class 12th

Question Type: NEET

Difficulty of question: Moderate

Expected time to solve: 30 secs

Topic: Genetics and Evolution

Concept: Genetic material

Sub-concept: The Search for Genetic Material

Concept field: The Search for Genetic Material

25. Select the correct Match:
- (1) Ribozyme - Nucleic acid
 - (2) F₂ × Recessive parent - Dihybrid cross
 - (3) T.H. Morgan - Transduction
 - (4) G. Mendel - Transformation

Answer (1)

Sol. Ribozyme is a ribonucleic acid (RNA) enzyme that catalyzes a chemical reaction just like proteinaceous enzymes.

Class 12th

Question Type: NEET

Difficulty of question: Easy

Expected time to solve: 20 secs

Topic: Biotechnology and its Applications

Concept: Ethical Issues

Sub-concept: : Biopiracy

Concept field: Unauthorised Exploitation of Bio-resources

26. Use of bio resources by multinational companies and organisations without authorisation from the concerned country and its people is called

- (1) Bio-infringement (2) Biopiracy
(3) Biodegradation (4) Bio-exploitation

Answer (2)

Sol. Biopiracy is the term used to refer to the use of bio-resources by multinational companies and other organizations without proper authorization from the countries and people concerned without compensatory payment.

Class 12th

Question Type: NEET

Difficulty of question: Moderate

Expected time to solve: 30 secs

Topic: Biotechnology- Principles and Processes

Concept: Processes of Recombinant DNA Technology

Sub-concept: Amplification of Gene of Interest

Concept field: Polymerase Chain Reaction

27. The correct order of steps in Polymerase Chain Reaction (PCR) is

- (1) Extension, Denaturation, Annealing (2) Annealing, Extension, Denaturation
(3) Denaturation, Extension, Annealing (4) Denaturation, Annealing, Extension

Answer (4)

Sol. In PCR multiple copies of gene (or DNA) of interest is synthesized in vitro using two sets of primers and the enzyme DNA polymerase. In this process the replication of DNA is repeated many times and the correct sequence is denaturation, annealing and extension.

Class 11th

Question Type: NEET

Difficulty of question: Easy

Expected time to solve: 20 secs

Topic: Anatomy of Flowering Plants

Concept: Secondary Growth

Sub-concept: Secondary Growth in Stem

Concept field: Role of Vascular Cambium

28. Secondary xylem and phloem in dicot stem are produced by

- (1) Apical meristems
- (3) Phellogen

- (2) Vascular cambium
- (4) Axillary meristems

Answer (2)

Sol. Intravascular cambium is present between primary xylem and primary phloem in patches. At the time of secondary growth intravascular cambium and inter-vascular cambium make a complete cambial ring. This cambial ring produces phloem towards the periphery of the stem and xylem towards the inner side. New formed phloem and xylem are called secondary phloem and secondary xylem respectively.

Class 11th

Question Type: NEET

Difficulty of question: Easy

Expected time to solve: 20 secs

Topic: Morphology of Flowering Plants

Concept: Root

Sub-concept: Modified roots

Concept field: Respiratory roots

29. Pneumatophores occur in

(1) Halophytes

(2) Free-floating hydrophytes

(3) Carnivorous plants

(4) Submerged hydrophytes

Answer (1)

Sol. Halophytes are the plants found in marshy areas and such areas are deficient in oxygen. For proper root growth these need to respire regularly and oxygen is required for the said purpose. In order to get sufficient oxygen branches from the tap roots of the mangroves emerge out of the soil and bear numerous pores called pneumatophores which help in respiration.

Class 11th

Question Type: NEET

Difficulty of question: Easy

Expected time to solve: 20 secs

Topic: Morphology of Flowering Plants

Concept: Root

Sub-concept: Adventitious roots

Concept field: Tuberous root

30. Sweet potato is a modified

(1) Stem

(2) Adventitious root

(3) Tap root

(4) Rhizome

Answer (2)

Sol. Sweet potato is a modified adventitious root as it develops from the roots that arise from the nodes of the runner plant of sweat potato. It is swollen unevenly so is called tuberous root.

Class 11th

Question Type: NEET

Difficulty of question: Easy

Expected time to solve: 20 secs

Topic: Plant Kingdom

Concept: Tracheophytes

Sub-concept: Characteristics of Pteridophytes and Gymnosperms

Concept field: Gymnosperms

31. Which of the following statement is **correct**?

- (1) Ovules are not enclosed by ovary wall in gymnosperms
- (2) *Selaginella* is heterosporous, while *Salvinia* is homosporous
- (3) Horsetails are gymnosperms
- (4) Stems are usually unbranched in both *Cycas* and *Cedrus*

Answer (1)

Sol. In Gymnosperms the ovules are naked which are present on the female strobili.

Class 11th

Question Type: NEET

Difficulty of question: Easy

Expected time to solve: 15 secs

Topic: Diversity in the Living World

Concept: Characteristics of Organisms of Five Kingdoms

Sub-concept: General Characteristics

Concept field: General Characteristics

32. Select the **wrong** statement:

- (1) Cell wall is present in members of Fungi and Plantae
- (2) Mushrooms belong to Basidiomycetes
- (3) Pseudopodia are locomotory and feeding structures in Sporozoans
- (4) Mitochondria are the powerhouse of the cell in all Kingdoms except Monera

Answer (3)

Sol. Sporozoans demonstrate gliding movements for locomotion and feeding is by the process of osmosis which occurs by the general body surface.

Class 11th

Question Type: NEET

Difficulty of question: Easy

Expected time to solve: 20 secs

Topic: Anatomy of Flowering Plants

Concept: Root

Sub-concept: Anatomy of Taproot

Concept field: Endodermis

33. Casparian strips occur in

- (1) Epidermis (2) Pericycle (3) Cortex (4) Endodermis

Answer (4)

Sol. The endodermis is thick walled leaving few thin walled cells which lie at the opposite to xylem. The thickness of endodermal cells is due deposition of suberin.

Class 11th

Question Type: NEET

Difficulty of question: Easy

Expected time to solve: 20 secs

Topic: Anatomy of Flowering Plants

Concept: Secondary Growth

Sub-concept: Secondary Growth in Phenerogames

Concept field: Secondary Growth in Angiosperms

34. Plants having little or no secondary growth are
- | | |
|--------------|---------------------------|
| (1) Grasses | (2) Deciduous angiosperms |
| (3) Conifers | (4) Cycads |

Answer (1)

Sol. In Angiosperms secondary growth is not observed in monocot plants due to the absence of cambium. Grasses are monocots so secondary growth is absent.

Class 11th

Question Type: NEET

Difficulty of question: Moderate

Expected time to solve: 30 secs

Topic: Plant Kingdom

Concept: Cryptogamae

Sub-concept: Characteristics of Cryptogamae

Concept field: Types of Reproductive Units

35. Which one is **wrongly** matched?
- | | |
|----------------------------|-----------------------|
| (1) Uniflagellate gametes | - <i>Polysiphonia</i> |
| (2) Biflagellate zoospores | -Brown algae |
| (3) Gemma cups | - <i>Marchantia</i> |
| (4) Unicellular organism | - <i>Chlorella</i> |

Answer (1)

Sol. In general all the red algae produce non-motile gametes and spores. *Polysiphonia* is a red alga which produces non-motile gametes.

Class 11th

Question Type: NEET

Difficulty of question: Easy

Expected time to solve: 20 secs

Topic: The Living World

Concept: Taxonomic Aids

Sub-concept: Importance of Taxonomic Aids

Concept field: Importance of Taxonomic Aids

36. Match the items given in Column I with those in Column II and select the **correct** option given below:-

Column-I

(a) Herbarium

(b) Key

(c) Museum

Column-II

(i) It is a place having a collection of preserved plants and animals.

(ii) A list that enumerates methodically all the species found in an area with brief description aiding identification.

(iii) Is a place where dried and pressed plant specimens mounted on sheets are kept.

(d) Catalogue (iv) A booklet containing a list of characters and their alternates which are helpful in identification of various taxa.

	a	b	c	d
(1)	(i)	(iv)	(iii)	(ii)
(2)	(iii)	(ii)	(i)	(iv)
(3)	(ii)	(iv)	(iii)	(i)
(4)	(iii)	(iv)	(i)	(ii)

Answer (4)

Sol. Specification of each taxonomic aid is mentioned in column II.

Class 11th

Question Type: NEET

Difficulty of question: Easy

Expected time to solve: 20 secs

Topic: Plant Kingdom

Concept: Gymnosperms

Sub-concept: Reproduction in Gymnosperms

Concept field: Male Gametophyte

37. Winged pollen grains are present in

- (1) Mustard (2) *Cycas* (3) Mango (4) *Pinus*

Answer (4)

Sol. Gymnosperms produce winged pollen grains which are carried by the wind to the female gametophyte.

Class 11th

Question Type: NEET

Difficulty of question: Moderate

Expected time to solve: 30 secs

Topic: Biological Classification

Concept: Fungi

Sub-concept: Sexual reproduction in fungi

Concept field: Spores

38. After karyogamy followed by meiosis, spores are produced exogenously in

- (1) *Neurospora* (2) *Alternaria* (3) *Agaricus* (4) *Saccharomyces*

Answer (3)

Sol. In *Agaricus* the basidiospores are produced exogenously while in *Neurospora* and *Saccharomyces*, ascospores are produced endogenously. *Alternaria* does not show sexual reproduction.

Class 11th

Question Type: NEET

Difficulty of question: Moderate

Expected time to solve: 30 secs

Topic: Respiration in Plants

Concept: Aerobic Respiration

Sub-concept: TCA Cycle

Concept field: TCA Cycle

39. What is the role of NAD^+ in cellular respiration?
- (1) It functions as an enzyme
 - (2) It functions as an electron carrier
 - (3) It is a nucleotide source for ATP synthesis
 - (4) It is the final electron acceptor for anaerobic respiration

Answer (2)

Sol. NAD^+ is electron carrier in TCA cycle and gets reduced to NADH (stores energy) which enters into ETS releases the stored energy and gets oxidised.

Class 11th

Question Type: NEET

Difficulty of question: Easy

Expected time to solve: 20 secs

Topic: Biological Classification

Concept: Monera

Sub-concept: Bacteria

Concept field: Nutrition in Bacteria

40. Oxygen is **not** produced during photosynthesis by
- | | |
|----------------------------|-------------------|
| (1) Green sulphur bacteria | (2) <i>Nostoc</i> |
| (3) <i>Cycas</i> | (4) <i>Chara</i> |

Answer (1)

Sol. Green sulphur bacteria are anoxygenic phototropic bacteria which perform anoxygenic photosynthesis. These use H_2S in place of H_2O as hydrogen donor to manufacture carbohydrates during photosynthesis and so do not liberate oxygen.

Class 12th

Question Type: NEET

Difficulty of question: Easy

Expected time to solve: 15 secs

Topic: Reproduction in Flowering Plants

Concept: Stamens

Sub-concept: Pollen Grains

Concept field: Cryopreservation

41. Pollen grains can be stored for several years in liquid nitrogen having a temperature of
- | | | | |
|--------------------------|-------------------------|--------------------------|--------------------------|
| (1) -120°C | (2) -80°C | (3) -196°C | (4) -160°C |
|--------------------------|-------------------------|--------------------------|--------------------------|

Answer (3)

Sol. Live cells, tissues etc. are kept in a deep freeze at subzero temperatures for storage or preservation is called cryopreservation where temperature is -196°C . This process reduces genetic change and ceases other biological activities.

Class 11th

Question Type: NEET

Difficulty of question: Moderate

Expected time to solve: 30 secs

Topic: Mineral Nutrition

Concept: Micronutrients

Sub-concept: Absorption of ions

Concept field: Absorption of ions

42. In which of the following forms is iron absorbed by plants?

- (1) Ferric (2) Ferrous (3) Free element (4) Both ferric and ferrous

Answer (1)

Sol. Iron is absorbed by plants in the form of ferric ions.

Class 12th

Question Type: NEET

Difficulty of question: Easy

Expected time to solve: 20 secs

Topic: Reproduction in Flowering Plants

Concept: Fertilization

Sub-concept: Double fertilization

Concept field: Syngamy and Tripe Fusion

43. Double fertilization is

- (1) Fusion of two male gametes of a pollen tube with two different eggs
(2) Fusion of one male gamete with two polar nuclei
(3) Fusion of two male gametes with one egg
(4) Syngamy and triple fusion

Answer (4)

Sol. In angiosperms the pollen grain releases two male gametes inside the embryo sac. The first male gamete fuses with the egg cell (syngamy) and the second male gamete fuses with the two polar nuclei (triple fusion). There are two fusions inside the embryo sac (syngamy and triple fusion) so is called double fertilization.

Class 11th

Question Type: NEET

Difficulty of question: Moderate

Expected time to solve: 30 secs

Topic: Transport in Plants

Concept: Plant Water Relations

Sub-concept: Turgor pressure

Concept field: Role of K^+

44. Which of the following elements is responsible for maintaining turgor in cells?

- (1) Magnesium (2) Sodium (3) Potassium (4) Calcium

Answer (3)

Sol. Pressure exerted by fluid in a cell that presses the cell membrane against the cell wall is called turgor. Loss of turgor, resulting from the loss of water from plant cells,

causes flowers and leaves to wilt. Increased potassium ions and anion concentration in the guard cells causes endosmosis as a result stoma opens.

Class 12th

Question Type: NEET

Difficulty of question: Moderate

Expected time to solve: 20 secs

Topic: Organisms and Populations

Concept: Population Interactions

Sub-concept: Interspecific Interactions

Concept field: Mutualism

45. Which one of the following plants shows a very close relationship with a species of moth, where none of the two can complete its life cycle without the other?
(1) *Hydrilla* (2) *Yucca* (3) Banana (4) *Viola*

Answer (2)

Sol. *Yucca* plant shows a mutualistic relationship with the moth *Colpa aurea*. The moth lays its egg inside the ovarian cavity of the plant and in return, the plant gets pollinated as the moth visits another flower for laying eggs.

Class 12th

Question Type: NEET

Difficulty of question: Moderate

Expected time to solve: 25 secs

Topic: Human Reproduction

Concept: Pregnancy and Embryonic Development

Sub-concept: Placenta

Concept field: Role of Placenta

46. Hormones secreted by the placenta to maintain pregnancy are
(1) hCG, hPL, progesterones, prolactin
(2) hCG, hPL, estrogens, relaxin, oxytocin
(3) hCG, hPL, progesterones, estrogens
(4) hCG, progesterones, estrogens, glucocorticoids

Answer (3)

Sol. Placenta is connected to the embryo through an umbilical cord, it acts as an endocrine tissue and releases hCG, hPL, progesterone and estrogen hormones.

Class 12th

Question Type: NEET

Difficulty of question: Easy

Expected time to solve: 20 secs

Topic: Reproductive Health

Concept: Birth Control

Sub-concept: Methods of Birth Control

Concept field: Hormonal Methods

47. The contraceptive 'SAHELI'

- (1) blocks estrogen receptors in the uterus, preventing eggs from getting implanted.
- (2) increases the concentration of estrogen and prevents ovulation in females.
- (3) is an IUD.
- (4) is a post-coital contraceptive.

Answer (1)

Sol. contraceptive 'SAHELI' is an oral contraceptive for females which contains a non-steroidal preparation.

Class 12th

Question Type: NEET

Difficulty of question: Moderate

Expected time to solve: 20 secs

Topic: Human Reproduction

Concept: Gametogenesis

Sub-concept: Spermatogenesis

Concept field: Spermatogenesis

48. The difference between spermiogenesis and spermiation is
- (1) In spermiogenesis spermatids are formed, while in spermiation spermatozoa are formed.
 - (2) In spermiogenesis spermatozoa are formed, while in spermiation spermatids are formed.
 - (3) In spermiogenesis spermatozoa from Sertoli cells are released into the cavity of seminiferous tubules, while in spermiation spermatozoa are formed.
 - (4) In spermiogenesis spermatozoa are formed, while in spermiation spermatozoa are released from Sertoli cells into the cavity of seminiferous tubules.

Answer (4)

Sol. Spermatids are transformed into spermatozoa (sperms) by the process called spermiogenesis. While release of sperms from the seminiferous tubules is called spermiation.

Class 12th

Question Type: NEET

Difficulty of question: Tough

Expected time to solve: 40 secs

Topic: Human Reproduction

Concept: Embryogenesis

Sub-concept: Stages in Embryogenesis

Concept field: Stages in Embryogenesis

49. The amnion of mammalian embryo is derived from
- | | |
|------------------------------|---------------------------|
| (1) ectoderm and mesoderm | (2) endoderm and mesoderm |
| (3) mesoderm and trophoblast | (4) ectoderm and endoderm |

Answer (1)

Sol. Amnion is lined with ectoderm and covered with mesoderm, both are germ layers, the amnion contains a transparent fluid in which the embryo is suspended which provides a cushion against mechanical injury.

Class 12th

Question Type: NEET

Difficulty of question: Easy

Expected time to solve: 20 secs

Topic: Organisms and Populations

Concept: Populations

Sub-concept: Population Attributes

Concept field: Population Attributes

50. In a growing population of a country
- (1) pre-reproductive individuals are more than the reproductive individuals.
 - (2) reproductive individuals are less than the post-reproductive individuals.
 - (3) reproductive and pre-reproductive individuals are equal in number.
 - (4) pre-reproductive individuals are less than the productive individuals.

Answer (1)

Sol. In a growing population of a country pre-reproductive individuals will always be more than the reproductive individuals and such a population is called expanding population.

Class 12th

Question Type: NEET

Difficulty of question: Easy

Expected time to solve: 20 secs

Topic: Biodiversity and Conservation

Concept: Biodiversity Conservation

Sub-concept: Conservation

Concept field: Ex-situ

51. All of the following are included in 'Ex-situ conservation' except
- (1) Wildlife safari parks
 - (2) Sacred groves
 - (3) Botanical gardens
 - (4) Seed banks

Answer (2)

Sol. When the whole ecosystem is protected its biodiversity at all levels is protected and this approach is called *in situ* conservation.

Class 12th

Question Type: NEET

Difficulty of question: Moderate

Expected time to solve: 30 secs

Topic: Human Health and Diseases

Concept: Drugs

Sub-concept: Opioids

Concept field: Sources

52. Which part of poppy plant is used to obtain the drug, "Smack"?
- (1) Flowers
 - (2) Latex
 - (3) Roots
 - (4) Leaves

Answer (2)

Sol. Heroin, commonly called smack is chemically diacetylmorphine which is obtained by acetylation of morphine, extracted from the latex of poppy plant.

Class 12th

Question Type: NEET

Difficulty of question: Easy

Expected time to solve: 20 secs

Topic: Ecology

Concept: Pollution

Sub-concept: Environmental Pollution and Control

Concept field: Affects and Measures

53. Match the items given in Column I with those in Column II and select the correct option given below:

Column I		Column II	
a. Eutrophication	(i) UV-B radiation		
b. Sanitary landfill	(ii) Deforestation		
c. Snow blindness	(iii) Nutrient enrichment		
d. Jhum cultivation	(iv) Waste disposal		

	a	b	c	d
(1)	(ii)	(i)	(iii)	(iv)
(2)	(i)	(iii)	(iv)	(ii)
(3)	(iii)	(iv)	(i)	(ii)
(4)	(i)	(ii)	(iv)	(iii)

Answer (3)

Sol. Rise in nutrients like nitrogen and phosphorous in a water body results in its natural aging and promotes growth of aquatic organisms, this is eutrophication. In sanitary landfills wastes are filled into the trench after compaction. Slash and burn agriculture (Jhum cultivation) involves cutting and burning of forest trees, left over ash is used as fertilizer and the land is converted into agricultural land. This leads to deforestation. Cornea of human eye can absorb UV-B radiation and a high dose of it causes inflammation of cornea called snow-blindness.

Class 12th

Question Type: NEET

Difficulty of question: Easy

Expected time to solve: 15 secs

Topic: Organisms and Populations

Concept: Species Interactions

Sub-concept: Types

Concept field: Amensalism

54. Which one of the following population interactions is widely used in medical science for the production of antibiotics?

- (1) Commensalism (2) Mutualism (3) Parasitism (4) Amensalism

Answer (4)

Sol. Amensalism is the relationship between two organisms, where one is hurt and the other organism remains unaffected.

Class 11th

Question Type: NEET

Difficulty of question: Moderate

Expected time to solve: 30 secs

Topic: Cell - The Unit of Life

Concept: Endomembrane System

Sub-concept: Endoplasmic Reticulum

Concept field: Functions of ER

55. Which of the following events does not occur in rough endoplasmic reticulum?
- | | |
|--------------------------------|----------------------------|
| (1) Protein folding | (2) Protein glycosylation |
| (3) Cleavage of signal peptide | (4) Phospholipid synthesis |

Answer (4)

Sol. Phospholipid synthesis occurs in smooth endoplasmic reticulum.

Class 11th

Question Type: NEET

Difficulty of question: Moderate

Expected time to solve: 30 secs

Topic: Respiration in Plants

Concept: Cellular Respiration

Sub-concept: Mechanism

Concept field: Oxidative Phosphorylation

56. Which of these statements is **incorrect**?
- (1) Enzymes of TCA cycle are present in mitochondrial matrix.
 - (2) Glycolysis occurs in cytosol.
 - (3) Glycolysis operates as long as it is supplied with NAD that can pick up hydrogen atoms.
 - (4) Oxidative phosphorylation takes place in outer mitochondrial membrane.

Answer (4)

Sol. Oxidative phosphorylation takes place in the inner mitochondrial membrane.

Class 11th

Question Type: NEET

Difficulty of question: Easy

Expected time to solve: 15 secs

Topic: Cell - The Unit of Life

Concept: Cell Organelles

Sub-concept: Ribosomes

Concept field: Polysome

57. Many ribosomes may associate with a single mRNA to form multiple copies of a polypeptide simultaneously. Such strings of ribosomes are termed as
- | | |
|--------------|-----------------------|
| (1) Polysome | (2) Polyhedral bodies |
|--------------|-----------------------|

(3) Plastidome

(4) Nucleosome

Answer (1)

Sol. Polysome is formed when two or more ribosomes are attached to a complex of mRNA molecule.

Class 11th

Question Type: NEET

Difficulty of question: Moderate

Expected time to solve: 20 secs

Topic: Cell - The Unit of Life

Concept: Eukaryotic Cell

Sub-concept: Nucleus

Concept field: Chromosomes

58. Select the **incorrect** match:

- | | | |
|----------------------------------|---|-----------------------|
| (1) Lamp brush chromosomes | - | Diplotene bivalents |
| (2) Allosomes | - | Sex chromosomes |
| (3) Sub-meta centric chromosomes | - | L-shaped chromosomes |
| (4) Polytene chromosomes | - | Oocytes of amphibians |

Answer (4)

Sol. Polytene chromosomes are found in the larvae of flies and in the salivary glands of flies.



Class 11th

Question Type: NEET

Difficulty of question: Easy

Expected time to solve: 20 secs

Topic: Cell - The Unit of Life

Concept: Neuron

Sub-concept: Nissl Bodies

Concept field: Ultrastructure of Neuron

59. Nissl bodies are mainly composed of

- | | | |
|---------------------------|-----|------------------------|
| (1) Proteins and lipids | (2) | DNA and RNA |
| (3) Nucleic acids and SER | (4) | Free ribosomes and RER |

Answer (4)

Sol. Nissl bodies are also known as Nissl granules are found in the nerve cell body of the neurons which help in protein synthesis. They are made up of free ribosomes and rough endoplasmic reticulum (RER).

Class 11th

Question Type: NEET

Difficulty of question: Easy

Expected time to solve: 20 secs

Topic: Digestion and Absorption

Concept: Human Digestive System

Sub-concept: Dentation

Concept field: Technical Terms

60. Which of the following terms describe human dentition?
 (1) Thecodont, Diphyodont, Homodont
 (2) Thecodont, Diphyodont, Heterodont
 (3) Pleurodont, Monophyodont, Homodont
 (4) Pleurodont, Diphyodont, Heterodont

Answer (2)

Sol. In human beings:

Teeth are fixed in jaw socket, thecodont condition.
 Teeth appear twice in lifetime, diphyodont condition.
 Teeth are of four different types, heterodont condition.

Class 11th

Question Type: NEET

Difficulty of question: Easy

Expected time to solve: 20 secs

Topic: Excretion and Osmoregulation

Concept: Excretory System

Sub-concept: Disorders of the Excretory System

Concept field: Symptoms

61. Match the items given in Column I with those in Column II and select the correct

option given below:			
Column I		Column II	
(a) Glycosuria		(i) Accumulation of uric acid in joints	
(b) Gout		(ii) Mass of crystallised salts within the kidney	
(c) Renal calculi		(iii) Inflammation in glomeruli	
(d) Glomerular nephritis		(iv) Presence of glucose in urine	

- | | | | | |
|-----|------------|------------|------------|------------|
| | (a) | (b) | (c) | (d) |
| (1) | (iii) | (ii) | (iv) | (i) |
| (2) | (i) | (ii) | (iii) | (iv) |
| (3) | (ii) | (iii) | (i) | (iv) |
| (4) | (iv) | (i) | (ii) | (iii) |

Answer (4)

Sol. In column I disorders of the excretory system are mentioned and their possible cause or symptoms are given in column II.

Class 11th

Question Type: NEET

Difficulty of question: Easy

Expected time to solve: 20 secs

Topic: Excretion and Osmoregulation

Concept: Excretory System

Sub-concept: Parts

Concept field: Functions

62. Match the items given in Column I with those Column II and select the correct option given below:

Column I	Column II
-----------------	------------------

(Function)	(Part of Excretory System)
(a) Ultra filtration	(i) Henle's loop
(b) Concentration of urine	(ii) Ureter
(c) Transport of urine	(iii) Urinary bladder
(d) Storage of urine	(iv) Malpighian corpuscle
	(v) Proximal convoluted tubule

	(a)	(b)	(c)	(d)
(1)	(iv)	(v)	(ii)	(iii)
(2)		(iv)	(i)	(ii)
		(iii)	(3)	(v)
			(i)	(ii)
(4)	(v)	(iv)	(i)	(iii)

Answer (2)

Sol. Blood is filtered finely through three membranes in the Malpighian corpuscle i.e. endothelium of glomerular blood vessels, the epithelium of Bowman's capsule and the basement membrane. So, it is termed as ultra filtration. Volume of filtrate produced per day by the nephron is 180 litres and the urine released is about 1.5 litres. Maximum concentration of urine takes place in the Henle's Loop.

Ureters carry the urine from the kidneys to the urinary bladder.

Urine is stored in the urinary bladder until its walls start stretching and generate micturition reflex.

Class 12th

Question Type: NEET

Difficulty of question: Easy

Expected time to solve: 15 secs

Topic: Evolution

Concept: Evidences for Evolution

Sub-concept: Divergent Evolution

Concept field: Homology

63. The similarity of bone structure in the forelimbs of many vertebrates is an example of

(1) Homology

(2) Analogy

(3) Convergent evolution

(4) Adaptive radiation

Answer (1)

Sol. Homology indicates common ancestry and supports divergent evolution like fore limbs of whale and man have similar type of bones but are adapted to diverse habitat.

Class 12th

Question Type: NEET

Difficulty of question: Easy

Expected time to solve: 15 secs

Topic: Human Health and Diseases

Concept: Immunity

Sub-concept: Auto Immunity

Concept field: Alzheimer

64. Which of the following is **not** an autoimmune disease?

- (1) Psoriasis (2) Rheumatoid arthritis
(3) Alzheimer's disease (4) Vitiligo

Answer (3)

Sol. Alzheimer's disease is a progressive disease in which brain cell connections and the cells themselves degenerate and start dying. Memory loss and confusion are the main symptoms.

Class 12th

Question Type: NEET

Difficulty of question: Easy

Expected time to solve: 20 secs

Topic: Evolution

Concept: Evidences for Evolution

Sub-concept: Divergent Evolution

Concept field: Analogy

65. Among the following sets of examples for divergent evolution, select the **incorrect** option:

- (1) Forelimbs of man, bat and cheetah
(2) Heart of bat, man and cheetah
(3) Brain of bat, man and cheetah
(4) Eye of octopus, bat and man

Answer (4)

Sol. Analogy supports convergent evolution and eye of octopus and of mammals are analogous organs.

Class 12th

Question Type: NEET

Difficulty of question: Moderate

Expected time to solve: 30 secs

Topic: Principles of Inheritance and Variation

Concept: Inheritance of Traits

Sub-concept: Inheritance of Blood Groups

Concept field: Dominance and its Types

66. Which of the following characteristics represent 'Inheritance of blood groups' in humans?

- (a) Dominance (b) Co-dominance
(c) Multiple dominance (d) Incomplete dominance
(e) Polygenic inheritance
(1) b, c and e (2) a, b and c (3) b, d and e (4) a, c and e

Answer (2)

Sol. In human beings, blood group A is dominating trait so is blood group B. When two traits express their own types equally is called co-dominance and in a population when any particular trait is controlled by more than a pair of alleles where more than one allele is dominant it is termed as multiple dominance.

Class 12th

Question Type: NEET

Difficulty of question: Easy

Expected time to solve: 15 secs

Topic: Human Health and Diseases

Concept: Common Human Diseases

Sub-concept: Infectious Diseases

Concept field: Elephantiasis

67. In which disease does mosquito transmitted pathogen cause chronic inflammation of lymphatic vessels?

- (1) Elephantiasis (2) Ascariasis (3) Ringworm disease (4) Amoebiasis

Answer (1)

Sol. Female *Culex* mosquito and sometimes *Aedes* and *Anopheles* female mosquitoes transmit elephantiasis from an infected person to a healthy person.

Class 12th

Question Type: NEET

Difficulty of question: Easy

Expected time to solve: 15 secs

Topic: Microbes in Human Welfare

Concept: Microbes in Household Products

Sub-concept: Milk Products

Concept field: LAB

68. Conversion of milk to curd improves its nutritional value by increasing the amount of

- (1) Vitamin D (2) Vitamin A (3) Vitamin B₁₂ (4) Vitamin E

Answer (3)

Sol. Fresh milk when converted to curd by adding LAB, its nutritional quality increases by increasing vitamin B₁₂.

Class 11th

Question Type: NEET

Difficulty of question: Moderate

Expected time to solve: 20 secs

Topic: Chemical Control and Coordination

Concept: Adrenal Gland

Sub-concept: Adrenal Hormones

Concept field: Medullary Hormones

69. Which of the following is an amino acid derived hormone?

- (1) Epinephrine (2) Ecdysone (3) Estradiol (4) Estriol

Answer (1)

Sol. Epinephrine, is derived from the amino acid tyrosine and it triggers the fight-or-flight response.

Class 11th

Question Type: NEET

Difficulty of question: Moderate

Expected time to solve: 30 secs

Topic: Neural Control and Coordination

Concept: Central Neural System

Sub-concept: Brain

Concept field: Forebrain

70. Which of the following structures or regions is incorrectly paired with its function?
- (1) Medulla oblongata: controls respiration and cardiovascular reflexes.
 - (2) Limbic system : consists of fibre tracts that interconnect different regions of brain; controls movement.
 - (3) Hypothalamus : production of releasing hormones and regulation of temperature, hunger and thirst.
 - (4) Corpus callosum : band of fibres connecting left and right cerebral hemispheres.

Answer (2)

Sol. Limbic system, of the human brain is involved in our behavioural and emotional responses.

Class 11th

Question Type: NEET

Difficulty of question: Tough

Expected time to solve: 30 secs

Topic: Chemical Control and Coordination

Concept: Parathyroid Gland and Ovary

Sub-concept: Role of PTH and Estrogen

Concept field: Deficiency

71. Which of the following hormones can play a significant role in osteoporosis?
- (1) Aldosterone and Prolactin
 - (2) Progesterone and Aldosterone
 - (3) Estrogen and Parathyroid hormone
 - (4) Parathyroid hormone and Prolactin

Answer (3)

Sol. Deficiency of estrogen promotes the activity of osteoclasts (bone deforming) cells and deficiency of parathyroid hormone or PTH reduces calcium absorption into the bones. Thus, osteoporosis is triggered.

Class 11th

Question Type: NEET

Difficulty of question: Easy

Expected time to solve: 15 secs

Topic: Neural Control and Coordination

Concept: Sense Organs

Sub-concept: Human Eye

Concept field: Anatomy of Human Eye

72. The transparent lens in the human eye is held in its place by

- (1) ligaments attached to the ciliary body
- (2) ligaments attached to the iris
- (3) smooth muscles attached to the iris
- (4) smooth muscles attached to the ciliary body

Answer (1)

Sol. Suspensory ligaments attached to the ciliary body holds the transparent lens in the human eye.

Class 11th

Question Type: NEET

Difficulty of question: Moderate

Expected time to solve: 20 secs

Topic: Structural Organisation in Animals

Concept: Earthworm

Sub-concept: Reproduction in Earthworm

Concept field: Development of Offsprings

73. Which of the following animals does not undergo metamorphosis?

- (1) Earthworm
- (2) Tunicate
- (3) Moth
- (4) Starfish

Answer (1)

Sol. In earthworm the development is direct which means there are no larva and pupa stages.

 In metamorphosis relatively abrupt change in the animal's body structure occurs during development process of the young one.

Class 11th

Question Type: NEET

Difficulty of question: Easy

Expected time to solve: 20 secs

Topic: Animal Kingdom

Concept: Chordata

Sub-concept: Aves

Concept field: Characteristics

74. Identify the vertebrate group of animals characterized by crop and gizzard in its digestive system.

- (1) Amphibia
- (2) Reptilia
- (3) Aves
- (4) Osteichthyes

Answer (3)

Sol. In the digestive system of birds crop and gizzard are present. Gizzard stores food temporarily and in stomach food is broken into smaller particles.

Class 11th

Question Type: NEET

Difficulty of question: Easy

Expected time to solve: 20 secs

Topic: Biological Classification

Concept: Protista

Sub-concept: Chrysophytes

Concept field: Nutrition in Chrysophytes

75. Which of the following organisms are known as chief producers in the oceans?
(1) Dinoflagellates (2) Diatoms (3) Cyanobacteria (4) Euglenoids

Answer (2)

Sol. Phytoplanktons are the chief producers in oceans and diatoms are one of them. Most of the species of diatoms are photosynthetic.

Class 11th

Question Type: NEET

Difficulty of question: Moderate

Expected time to solve: 20 secs

Topic: Animal Kingdom

Concept: Chordata

Sub-concept: Reptilia

Concept field: General Characteristics

76. Which one of these animals is not a homeotherm?

(1) *Macropus* (2) *Chelone* (3) *Camelus* (4) *Psittacula*

Answer (2)

Sol. *Chelone*, a green sea turtle is poikilothermic animal.

Class 11th

Question Type: NEET

Difficulty of question: Moderate

Expected time to solve: 30 secs

Topic: Biological Classification

Concept: Protista

Sub-concept: Protozoa

Concept field: Characteristics of Protozoa

77. Ciliates differ from all other protozoans in

- (1) using flagella for locomotion
- (2) having a contractile vacuole for removing excess water
- (3) using pseudopodia for capturing prey
- (4) having two types of nuclei

Answer (4)

Sol. In ciliates like *Paramecium* there are two nuclei one is called micro-nucleus and the other is called macro-nucleus.

Class 11th

Question Type: NEET

Difficulty of question: Moderate

Expected time to solve: 25 secs

Topic: Structural Organisation in Animals

Concept: Cockroach

Sub-concept: Morphology of Cockroach

Concept field: Sexual Dimorphism

78. Which of the following features is used to identify a male cockroach from a female cockroach?

- (1) Presence of a boat shaped sternum on the 9th abdominal segment
- (2) Presence of caudal styles
- (3) Forewings with darker tegmina
- (4) Presence of anal cerci

Answer (2)

Sol. In male cockroach caudal styles and anal cerci both are present on the ninth abdominal segment.

Class 11th

Question Type: NEET

Difficulty of question: Moderate

Expected time to solve: 25 secs

Topic: Breathing and Exchange of Gases

Concept: Respiratory System

Sub-concept: Disorders of Respiratory System

Concept field: Conditions

79. Which of the following options correctly represents the lung conditions in asthma and emphysema, respectively?

- (1) Inflammation of bronchioles, decreased respiratory surface
- (2) Increased number of bronchioles; increased respiratory surface
- (3) Increased respiratory surface, inflammation of bronchioles
- (4) Decreased respiratory surface, inflammation of bronchioles

Answer (1)

Sol. In asthma the bronchi and bronchioles are inflamed which causes difficulty in breathing. In emphysema the alveolar walls get damaged and turn inelastic in nature, thus decrease the surface area for gaseous exchange.

Class 11th

Question Type: NEET

Difficulty of question: Easy

Expected time to solve: 15 secs

Topic: Body Fluids and Circulation

Concept: Human Circulatory System

Sub-concept: Heart

Concept field: Valves

80. Match the items given in Column I with those in Column II and select the correct option given below:

Column I

Column II

- | | |
|----------------------|---|
| (a) Tricuspid valve | (i) Between left atrium and left ventricle |
| (b) Bicuspid valve | (ii) Between right ventricle and pulmonary artery |
| (c) Semi lunar valve | (iii) Between right atrium and right ventricle |
- (a) (b) (c)
- (1) (iii) (i) (ii)
 - (2) (i) (iii) (ii)
 - (3) (i) (ii) (iii)
 - (4) (ii) (i) (iii)

Answer (1)

Sol. In heart the valve present between right atrium and right ventricle has three cusps, the valve present between left atrium and left ventricle has two cusps and is also known as mitral valve. At the base of pulmonary artery arch shaped valves with two cusps are present. These valves prevent back flow of blood.

Class 11th

Question Type: NEET

Difficulty of question: Moderate

Expected time to solve: 20 secs

Topic: Breathing and Exchange of Gases

Concept: Mechanism of Breathing

Sub-concept: Respiratory Volumes and Capacities

Concept field: Respiratory Volumes and Capacities

81. Match the items given Column I with those in Column II and select the correct option given below.

Column I

- (a) Tidal volume
- (b) Inspiratory Reserve volume
- (c) Expiratory Reserve volume
- (d) Residual volume

Column II

- (i) 2500-3000 mL
- (ii) 1100-1200 mL
- (iii) 500-550 mL
- (iv) 1000-1100 mL

- | | (a) | (b) | (c) | (d) |
|-----|-------|-------|------|-------|
| (1) | (iii) | (ii) | (i) | (iv) |
| (2) | (iii) | (i) | (iv) | (ii) |
| (3) | (i) | (iv) | (ii) | (iii) |
| (4) | (iv) | (iii) | (ii) | (i) |

Answer (2)

Sol. The amount of air taken in at rest is TV (500-550 ml).

The amount of air which can be forcefully inhaled after normal inhalation is IRV (2500-3000 ml).

The amount of air which can be forcefully exhaled after normal exhalation is ERV (1000-1100 ml).

The amount of air which cannot be exhaled even after forceful exhalation is RV (1100-1200 ml).

Class 12th

Question Type: NEET

Difficulty of question: Moderate

Expected time to solve: 30 secs

Topic: Molecular Basis of Inheritance

Concept: Transcription

Sub-concept: Transcription Unit

Concept field: Transcription Unit

82. AGGTATCGCAT is a sequence from the coding strand of a gene. What will be the corresponding sequence of the transcribed mRNA?

- (1) AGGUAUCGCAU (2) UGGTUTCGCAT (3) ACCUAUGCGAU
 (4) UCCAUAGCGUA

Answer (4)

Sol. In RNA uracil is present in place of thymine. So as per the complimentary base pair rule (A-U/T and G-C) the base sequence mRNA will be- UCCAUAGCGUA

Class 12th

Question Type: NEET

Difficulty of question: Moderate

Expected time to solve: 20 secs

Topic: Evolution

Concept: Mechanism of Evolution

Sub-concept: Mutation

Concept field: Saltation

83. According to Hugo de Vries, the mechanism of evolution is:-

- (1) Multiple step mutations (2) Saltation
 (3) Phenotypic variations (4) Minor mutations

Answer (2)

Sol. Saltation (L. *Saltus* means 'leap') is a sudden and large mutational change from one generation to the next generation which leads to evolution.

Class 12th

Question Type: NEET

Difficulty of question: Easy

Expected time to solve: 20 secs

Topic: Human Reproduction

Concept: Menstrual Cycle

Sub-concept: Events during Menstrual Cycle

Concept field: Specifications

84. Match the items given in Column I with those in Column II and select the correct option given below

Column I

- (a) Proliferative Phase
 (b) Secretory Phase
 (c) Menstruation

Column II

- (i) Breakdown of endometrial lining
 (ii) Follicular Phase
 (iii) Luteal Phase

- (a) (b) (c)
 (1) (iii) (ii) (i)
 (2) (i) (iii) (ii)
 (3) (ii) (iii) (i)
 (4) (iii) (i) (ii)

Answer (3)

Sol. The reproductive cycle in the female primates is called menstrual cycle and it is repeated at the interval of 28 or 29 days. Various events of the menstrual cycle are:

Proliferative phase also called follicular phase during which the endometrial lining start regenerating. During secretory phase also called luteal phase the secretion of estrogen by the growing follicles increases under the influence of gonadotropins, release of ovum takes place and corpus luteum starts developing. If fertilization does not occur then the menstruation starts during which the proliferated endometrial lining is broken down and released out of the body.

Class 12th

Question Type: NEET

Difficulty of question: Moderate

Expected time to solve: 20 secs

Topic: Principles of Inheritance and Variation

Concept: Genetic Disorders

Sub-concept: Mendelian Disorders

Concept field: Sex Linked Inheritance of Traits

85. A woman has an X-linked condition on one of her X chromosomes. This chromosome can be inherited by:-
(1) Only daughters (2) Only sons (3) Only grandchildren (4) Both sons and daughters

Answer (4)

Sol. In human females the 23rd pair (sex chromosomes) of chromosome is represented as XX. So any X-linked condition on one of her X chromosome can be inherited either by sons or daughters.

Class 12th

Question Type: NEET

Difficulty of question: Moderate

Expected time to solve: 25 secs

Topic: Molecular Basis of Inheritance

Concept: Regulation of Gene Expression

Sub-concept: Operon

Concept field: Polycistronic Structural Gene

86. All of the following are part of an operon **except**
(1) an operator (2) structural genes
(3) an enhancer (4) a promoter

Answer (3)

Sol. No enhancer gene is present in an operon.

Class 11th

Question Type: NEET

Difficulty of question: Moderate

Expected time to solve: 30 secs

Topic: Digestion and Absorption

Concept: Digestive Glands

Sub-concept: Gastric Glands

Concept field: Functions of Gastric Glands

87. Which of the following gastric cells indirectly help in erythropoiesis?
(1) Chief cells (2) Mucous cells (3) Goblet cells (4) Parietal cells

Answer (4)

Sol. The intrinsic factor (IF) is a glycoprotein produced by the parietal cells (oxyntic cells) located at the gastric body and fundus. Intrinsic factor plays a crucial role in the transportation and absorption of the vitamin B12 (cobalamin). Erythroblasts require folate and vitamin B12 for proliferation during their differentiation and help in maturing.

Class 11th

Question Type: NEET

Difficulty of question: Moderate

Expected time to solve: 30 secs

Topic: Biomolecules

Concept: Proteins

Sub-concept: Types of Proteins

Concept field: Functions of Proteins

88. Match the items given in Column I with those in Column II and select the correct option given below:-

Column I

(a) Fibrinogen

(b) Globulin

(c) Albumin

(a) (b) (c)

(1) (iii) (ii) (i)

(2) (i) (ii) (iii)

(3) (i) (iii) (ii)

(4) (ii) (iii) (i)

Column II

(i) Osmotic balance

(ii) Blood clotting

(iii) Defence mechanism

Answer (4)

Sol. Fibrinogen is a glycoprotein found in soluble state in the blood but precipitates into insoluble fibrin by a series of reactions during blood clotting to prevent blood loss.

Globulin is an example of tertiary protein which help in defence mechanism.

Albumin is a tertiary protein which helps the body to maintain intravascular colloid osmotic pressure, neutralize toxins, and transport therapeutic agents.

Class 11th

Question Type: NEET

Difficulty of question: Tough

Expected time to solve: 35 secs

Topic: Movement and Locomotion

Concept: Muscle Contraction

Sub-concept: Mechanism of Muscle Contraction

Concept field: Role of Calcium

89. Calcium is important in skeletal muscle contraction because it

- (1) binds to troponin to remove the masking of active sites on actin for myosin.
- (2) activates the myosin ATPase by binding to it.
- (3) detaches the myosin head from the actin filament.
- (4) prevents the formation of bonds between the myosin cross bridges and the actin filament.

Answer (1)

Sol. Striated muscle in the relaxed state has tropomyosin covering myosin-binding sites on actin filaments. Calcium binds to troponin C, which removes the masking of active sites for myosin. Myosin heads bind to the exposed active sites on actin filament to form cross bridges and pull the actin filaments, thus muscle contraction occurs.

Class 11th

Question Type: NEET

Difficulty of question: Easy

Expected time to solve: 15 secs

Topic: Respiration and Breathing

Concept: Respiratory System

Sub-concept: Respiratory Disorders

Concept field: Occupational Respiratory Disorders

90. Which of the following is an occupational respiratory disorder?



- (1) Anthracis (2) Silicosis (3) Botulism (4) Emphysema

Answer (2)

Sol. Silicosis is an interstitial lung disease caused by breathing in tiny bits of silica, a common mineral found in many types of rock and soil. People working in marble industry and are involved in cutting and grinding of stones suffer from silicosis.